

Toshiba Personal Computer
Satellite A80/A85
Maintenance Manual

TOSHIBA CORPORATION

[CONFIDENTIAL]

Copyright

© 2004 by Toshiba Corporation. All rights reserved. Under the copyright laws, this manual cannot be reproduced in any form without the prior written permission of Toshiba. No patent liability is assumed with respect to the use of the information contained herein.

Toshiba Personal Computer Satellite A80/A85 Maintenance Manual

First edition September 2004

Disclaimer

The information presented in this manual has been reviewed and validated for accuracy. The included set of instructions and descriptions are accurate for the A80/A85 Series at the time of this manual's production. However, succeeding computers and manuals are subject to change without notice. Therefore, Toshiba assumes no liability for damages incurred directly or indirectly from errors, omissions, or discrepancies between any succeeding product and this manual.

Trademarks

IBM is a registered trademark, and OS/2 and PS/2 are trademarks of IBM Corporation. Microsoft, MS-DOS, Windows, DirectSound and DirectMusic are registered trademarks of Microsoft Corporation.

Intel and Pentium are registered trademarks, and SpeedStep is a trademark of Intel Corporation. Sound Blaster is a registered trademark of Creative Technology Ltd.

Centronics is a registered trademark of Centronics Data Computer Corporation.

Photo CD is a trademark of Eastman Kodak.

All other properties are trademarks or registered trademarks of their respective holders.

Preface

This maintenance manual describes how to perform hardware service maintenance for the Toshiba Personal Computer Satellite SATELLITE A80/A85, referred to as the A80/A85 Series in this manual.

The procedures described in this manual are intended to help service technicians isolate faulty Field Replaceable Units (FRUs) and replace them in the field.

SAFETY PRECAUTIONS

Four types of messages are used in this manual to bring important information to your attention. Each of these messages will be italicized and identified as shown below.

DANGER: “Danger” indicates the existence of a hazard that could result in death or serious bodily injury if the safety instruction is not observed.

WARNING: “Warning” indicates the existence of a hazard that could result in bodily injury if the safety instruction is not observed.

CAUTION: “Caution” indicates the existence of a hazard that could result in property damage if the safety instruction is not observed.

NOTE: “Note” contains general information that relates to your safe maintenance service.

Improper repair of the computer may result in safety hazards. Toshiba requires service technicians and authorized dealers or service providers to ensure the following safety precautions are adhered to strictly.

- Be sure to fasten screws securely with the right screwdriver. If a screw is not fully fastened, it could come loose, creating a danger of a short circuit, which could cause overheating, smoke or fire.
- If you replace the battery pack or RTC battery, be sure to use only the same model battery or an equivalent battery recommended by Toshiba. Installation of the wrong battery can cause the battery to explode.

The manual is divided into the following parts:

- Chapter 1 Hardware Overview describes the A80/A85 Series system unit and each FRU.
- Chapter 2 Troubleshooting Procedures explains how to diagnose and resolve FRU problems.
- Chapter 3 Test and Diagnostics describes how to perform test and diagnostic operations for maintenance service.
- Chapter 4 Replacement Procedures describes the removal and replacement of the FRUs.
- Appendices The appendices describe the following:

- Handling the LCD module
- Board layout
- Pin assignments
- Keyboard scan/character codes
- Key layout
- Screw torque list
- Reliability

Conventions

This manual uses the following formats to describe, identify, and highlight terms and operating procedures.

Acronyms

On the first appearance and whenever necessary for clarification acronyms are enclosed in parentheses following their definition. For example:

Read Only Memory (ROM)

Keys

Keys are used in the text to describe many operations. The key top symbol as it appears on the keyboard is printed in **boldface** type.

Key operation

Some operations require you to simultaneously use two or more keys. We identify such operations by the key top symbols separated by a plus (+) sign. For example, **Ctrl + Pause (Break)** means you must hold down **Ctrl** and at the same time press **Pause (Break)**. If three keys are used, hold down the first two and at the same time press the third.

User input

Text that you are instructed to type in is shown in the boldface type below:

DISKCOPY A: B:

The display

Text generated by the computer that appears on its display is presented in the type face below:

```
Format complete
System transferred
```

Table of Contents

Chapter 1 Hardware Overview

1.1	Features	1-1
1.2	System Unit.....	1-5
1.3	2.5-inch Hard Disk Drive.....	1-9
1.4	Removable Drives.....	1-10
1.5	Power Supply	1-16
1.6	Batteries	1-18

Chapter 2 Troubleshooting Procedures

2.1	Troubleshooting Introduction	2-1
2.2	Troubleshooting Flowchart.....	2-2
2.3	Power Supply Troubleshooting	2-7
2.4	Display Troubleshooting.....	2-12
2.5	Keyboard Troubleshooting	2-15
2.6	External USB Devices Troubleshooting.....	2-17
2.7	TV-Out Failure Troubleshooting	2-19
2.8	Printer Port Troubleshooting	2-21
2.9	TouchPad Troubleshooting.....	2-23
2.10	Speaker Troubleshooting	2-25
2.11	Optical Drive Troubleshooting	2-27
2.12	Modem Troubleshooting.....	2-30
2.13	PCMCIA Troubleshooting.....	2-32
2.14	IEEE 1394 Troubleshooting	2-34
2.15	Wireless LAN Troubleshooting.....	2-36

Chapter 3 Tests and Diagnostics

3.1	The Diagnostic Test	3-1
3.2	Executing the Diagnostic Test.....	3-2
3.3	Config Check Test.....	3-6
3.4	DMI Check Test	3-7
3.5	PIO Loopback Test.....	3-8
3.6	IEEE 1394 Test	3-9
3.7	Speaker Audio Test	3-10
3.8	Fan ON/OFF Test.....	3-11
3.9	Main Battery Charge Test	3-12
3.10	FDD Test	3-13
3.11	CD-ROM Test	3-14
3.12	Keyboard Test	3-15
3.13	Mouse (Pad) Test	3-17
3.14	LCD Pixels Mode Test.....	3-19
3.15	Lid Switch Test	3-20
3.16	HDD R/W Test.....	3-21
3.17	LAN Test.....	3-23
3.18	RTC Test	3-25
3.19	CD Control Button Test	3-26

Chapter 4 Replacement Procedures

4.1	General.....	4-1
4.2	Battery.....	4-7
4.3	PC Card.....	4-9
4.4	HDD.....	4-11
4.5	Optical Drive Module.....	4-13
4.6	Optical Drive.....	4-15
4.7	Wireless LAN Unit.....	4-17
4.8	Expansion Memory.....	4-20
4.9	Keyboard.....	4-23
4.10	Modem.....	4-26
4.11	Display Assembly.....	4-28
4.12	Touch Cover.....	4-31
4.13	Touch Pad.....	4-34
4.14	Speakers.....	4-36
4.15	System Board.....	4-37
4.16	Fan, Heat Sink, & CPU.....	4-39
4.17	Display Mask.....	4-42
4.18	LCD Module.....	4-44
4.19	FL Inverter Board.....	4-47

Appendices

Appendix A Handling the LCD Module..... A-1
Appendix B Board Layout..... B-1
Appendix C Pin Assignments C-1
Appendix D Keyboard Scan/Character Codes..... D-1
Appendix E Key Layout E-1
Appendix F Series Screw Torque List F-1
Appendix G Reliability G-1

Chapter 1

Hardware Overview

Chapter 1 Contents

1.1	Features	1-5
1.2	System Unit.....	1-9
1.3	2.5-inch Hard Disk Drive.....	1-11
1.4	Optical device Drives.....	1-12
1.4.1	DVD-ROM & CD-RW	1-12
1.4.2	DVD Super Multi Double Layer	1-13
1.5	Power Supply	1-14
1.6	Batteries	1-16
1.6.1	Main Battery.....	1-17
1.6.2	RTC battery	1-18

Figures

Figure 1-1	2.5-inch HDD	1-11
------------	--------------------	------

Table

Table 1-1	2.5-inch HDD specifications	1-11
Table 1-2	DVD-ROM & CD-RW drive specifications	1-12
Table 1-3	DVD Super Multi drive specifications	Error! Bookmark not defined.
Table 1-4	DVD Super Multi Double Layer drive specifications	1-13

1.1 Features

The Satellite A80/A85 Series Personal Computer uses extensive Large Scale Integration (LSI), and Complementary Metal-Oxide Semiconductor (CMOS) technology extensively to provide compact size, minimum weight and high reliability. This computer incorporates the following features and benefits:

- ❑ CPU
 - Intel Celeron M CPU 350J (1.3GHz) / 360J (1.4GHz) / 370(1.5GHz), 0.09u, 1M L2, FSB 400MHz
- ❑ Chipset
 - ATi RL300MB (400 MHz FSB supported)
 - ATI IXP150
 - ENE KB910 for Keyboard Controller, Battery management Unit, and RTC.
 - TI PCI1410 for Card Bus PCMCIA controller.
 - Realtek ALC250VD for AC97 Codec.
 - Realtek RTL8100CL for 10/100M LAN
- ❑ Memory
 - Support DDR1 333MHz, No support Dual Channel.
 - Two SODIMM with 256MB/512MB/1GB, one socket on upper of PCB, another socket on bottom of PCB.
 - Easy upgrade from bottom side, Max. 2GB
 - Integrated Gfx supported by ATI RL300MB
 - Support 16/32/64/128MB UMA VGA Memory
 - Default VRAM size: 64MB
- ❑ BIOS
 - 512KB Flash ROM for system BIOS.
 - Suspend to RAM/Disk.
 - Password protection (System).
 - Windows 98 ready with PnP
 - Various hot key for system control.
 - Refreshable
 - Complete ACPI 1.0B Function

- ❑ Power
 - 4 cells Li-Ion 18650 size smart battery Pack with 14.4 Vx2000mAh
 - 8 cells Li-Ion 18650 size smart battery Pack with 14.4 Vx4300mAh
- ❑ HDD
 - 9.5mm, 2.5" HDD up to 120 GB
 - Bus Master IDE
 - 9.5m/m, 2.5" HDD Support
 - Support Ultra 100 synchronous DMA
- ❑ Fixed Device Drivers
 - Fixed bay
 - CD-RW/DVD-ROM, DVD-RAM/-R/-RW readable
 - DVD Super Multi Dual-Layer Recording:
 - 5/8/4/8/4/2.4x (write speed of DVD-RAM/-R/-RW/+R/+RW/+R DL)
- ❑ Optional Devices
 - 128MB/256MB/512MB/1024MB SO-DIMM modules
 - Dual-Band builds in Antenna for Wireless LAN Communication.
- ❑ Keyboard

The computer's keyboard layouts are compatible with a 101/102-key enhanced keyboard. There are five types of keys: typewriter keys, keypad overlay, function keys, soft keys and cursor control keys. The typewriter keys and keypad overlay keys are black. The other keys are dark gray.
- ❑ TouchPad

This pointing control device, located in the center of the keyboard palm-rest, provides convenient control of the cursor without requiring desk space for a mouse. The TouchPad incorporates two mouse buttons.

- ❑ Display
 - 15.0" TFT screen with a resolution of 1024 horizontal x 768 vertical pixels XGA
- ❑ I/O Ports
 - One 15 pins CRT port
 - One MIC In port
 - One headphone-out
 - One 2pins AC Adapter Jack
 - One type II PCMCIA Card Bus slots with shutter door
 - Three 4 pins USB 2.0 ports
 - One RJ11/RJ45 Port
 - VR for volume control

- ❑ PCMCIA Card Organization
 - One type II card sockets
 - 1.8" 10.5mm removable ATA Device
 - Card bus card or PC Care with hot insertion and removal
 - ACPI 1.1 Compliant.
 - Support 5V/3.3V PC Cards and 3.3V Cardbus cards.
 - Supports PCMCIA-ATA Specification.
- ❑ Universal Serial Bus (USB)

The computer has three Universal Serial Bus (USB) ports that comply with the USB 2.0 standard, which enable data transfer speeds more than 40 times faster than USB 1.1 (which this computer also supports.) The USB drives may be used to transfer data at Low, Full, and high speeds.
- ❑ External monitor port

A 15-pin CRT port supporting DDC 2B enables connection of an external monitor, which is recognized automatically by Video Electronics Standards Association (VESA) Display Data Channel (DDC) compatible functions.
- ❑ Sound system

Windows® Operating System compatible sound system provides internal speakers as well as jacks for an external microphone and headphone.
- ❑ TV-out port

This video-out mini-jack enables transfer of NTSC or PAL data (video and right/left audio) to external devices such as a TV.
- ❑ LAN port

The computer comes with an RJ-45 Local Area Network (LAN) port. The LAN port provides connectivity for LAN.

1.2 System Unit

The system unit is composed of the following major components:

- ❑ Processor
 - Intel Celeron M CPU up to 1.5GHZ 0.09u, 1M L2, FSB 400MHz
 - Micro FC-PGA package CPU
- ❑ System Logic
 - ATI RL300MB (400 MHz FSB supported)
 - ATI IXP150
 - ENE KB910 for Keyboard Controller, Battery management Unit, and RTC.
 - TI PCI1410 for Card Bus PCMCIA controller.
 - Integrated VGA solution for RL300MB
 - Realtek ALC250VD for AC97 Codec.
 - Realtek RTL8100CL for 10/100M LAN
 -
- ❑ Keyboard Controller
 - ENE KB910 is use as Keyboard Controller and Battery management unit.
- ❑ Memory
 - Support DDR1 333MHz, No support Dual Channel.
 - Two SODIMM with 256MB/512MB/1GB, one socket on upper of PCB, another socket on bottom of PCB.
 - Easy upgrade from bottom side, Max. 2GB
 - Integrated Gfx supported by ATI RL300MB
 - Support 16/32/64/128MB UMA VGA Memory
 - Default VRAM size: 64MB.

□ Audio subsystem

- Support of S'PDIF out is fully compliant with AC'97 rev2.3 specifications.
- 20-bit Stereo Digital-to-Analog Converters.
- 18-bit Stereo Analog-to- Digital Converters.
- Built-in 7 Bands of Digital Hardware Equalizer for Optimizing Speaker Response.
- Supports double sampling rate(96KHz) of DVD audio playback.
- Two Analog Line-level Stereo inputs with LIN_IN, CD, and AUX.
- Two Analog Line-level Mono Input: PCBEEP, PHONE-IN.
- Two software selectable MIC inputs.
- High quality differential CD Input.
- Power management and enhanced power saving features.
- Meets Microsoft WHQL/WLP 2.0 audio requirements.
- HRTF 3D positional audio.
- 3D Stereo Enhancement.

1.3 2.5-inch Hard Disk Drive

The internal HDD is a random access non-volatile storage device. It has a non-removable 2.5-inch magnetic disk and mini-Winchester type magnetic heads. The computer supports up to 100GB HDD.

The HDD is shown in Figure 1-1. Specifications are listed in Table 1-1

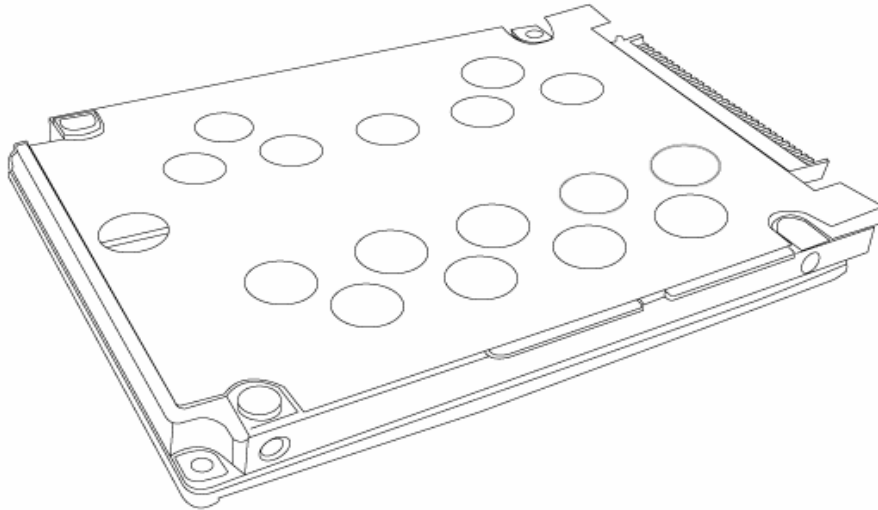

Figure 1-1 2.5-inch HDD

Items	40GB	60GB	80GB	100GB
Formatted capacity (GB)	37.26	55.89	74.52	93.15
Logical Blocks (LBA)	78,125,000	117,187,500	156,301,488	195,371,568
Rotational speed (rpm)	4,200/5400	4,200/5400	4200/5400	4200/5400
Toshiba HDD Buffer (MB)	8/16	8/16	8/16	8/16
Hitachi HDD Buffer (MB)	2/8	8/8	8/8	NA/8
Bytes per sector	512	512	512	512

Table 1-1 2.5-inch HDD specifications

1.4 Optical device Drives

- DVD-ROM & CD-RW drive
- DVD Super Multi drive

1.4.1 DVD-ROM & CD-RW

The DVD Super Multi drive accepts 12-cm (4.72-inch) and 8-cm (3.15-inch) discs. At maximum, the drive can play back a DVD at 8x speed, read CD-ROM at 24x speed, and write CD-R at 24x speed and CD-RW at 4x speed or High speed CD-RW at 10X or Ultra speed CD-RW at 24X speed.

The specifications of the DVD-ROM & CD-RW drive are listed in Table 1-2.

Item	DVD-ROM mode	CD-ROM mode
Data transfer rate (Mbytes/s)	33.3 (U-DMA transfer mode 2) 16.6 (PIO mode 4, Multiword DMA mode 2)	
Access time (ms) Average random access	180	150
Data buffer size (Mbytes)	2MB	
Formats supported	DVD: DVD-VIDEO, DVD-ROM, DVD-R (3.9G,4.7G), DVD-RW (Ver.1.1), DVD-RAM, DVD+R, DVD+RW, DVD+R DL. CD: CD-DA, CD-ROM, CD-R, CD-RW, CD-ROMXA, PhotoCD (muitiSession), Video CD, CD-Extra (CD+), CD-Text	

Table 1-2 DVD-ROM & CD-RW drive specifications

1.4.2 DVD Super Multi Double Layer

The DVD Super Multi drive accepts 12-cm (4.72-inch) and 8-cm (3.15-inch) discs. At maximum, the drive can play back a DVD at 8x speed, read CD-ROM at 24x speed, and write CD-R at 24x speed and CD-RW at 4x speed or Ultra and High speed CD-RW at 10x speed and DVD-R at 8x speed and DVD-RW at 4x speed and DVD+R at 8x speed and DVD+RW at 4x speed and DVD-RAM at 5x speed and DVD+R DL at 2.4x speed.

The specifications of the DVD Super Multi Double Layer drive are listed in Table 1-3

Item	DVD-ROM mode	CD-ROM mode
Data transfer rate (Mbytes/s)	33.3 (U-DMA transfer mode 2) 16.6 (PIO mode 4, Multiword DMA mode 2)	
Access time (ms) Average random access	180	150
Data buffer size (Mbytes)	2MB	
Formats supported	DVD: DVD-VIDEO, DVD-ROM, DVD-R (4.7G), DVD-RW (Ver.1.1), DVD-RAM, DVD+R, DVD+RW, DVD+R DL. CD: CD-DA, CD-ROM, CD-R, CD-RW, CD-ROMXA, PhotoCD (multiSession), Video CD, CD-Extra (CD+), CD-Text	

Table 1-3 DVD Super Multi Double Layer drive specifications

1.5 Power Supply

This specification defines the performance and characteristic of 65W and 75W AC adapter power supply. It supplies a constant voltage 19V output source for A80/A85 series notebook computer.

- ❑ A/D conversion
 - The EC uses 10-bit sampling for A/D conversion to determine the following values:
 - AC adaptor current
 - Battery and temperature

- ❑ AC adaptor and battery check
 - The EC checks the following by A/D converted values:
 - Battery installed
 - The EC checks the following by GPIO values:
 - AC adaptor connected

- ❑ Abnormal check
 - The EC determines whether the condition is abnormal, and if so, stores an error code into the error register.

- ❑ Input port management
 - The EC monitors the following input signal status:
 - System power ON/OFF status
 - Direct CD power ON/OFF status

- ❑ Beep and LED control
 - Beep is caused by the low battery status.
 - The EC controls the following two kinds of LED
 - DC IN LED (one color: green)
 - Green = indicates AC adaptor is connected
 - Battery LED (two colors: orange and green)
 - Green solid = The battery is fully charged.
 - Orange = The computer is quick-charging the battery / The battery is low.

- ❑ Power ON/OFF sequence
 - When power is turned on or off, the EC starts the power on or off sequence.
 - SQ0-4 = power ON sequence
 - SQ5-B = power OFF sequence

- ❑ Battery charging control
 - The EC controls the following.
 - The quick charging ON/OFF
 - The detection of full charge

- ❑ Detection of the low battery
 - The EC detects the low battery point by the gas gauge.
 - LB10M = The system will be driven by the battery for 12 more minutes.
 - LB0 = The battery won't be able to drive the system after 3 minutes.
 - LB1 = The battery can drive the system only during the suspend process.
 - LB2 = The battery cannot drive the system.

- ❑ New battery installation
 - When a new battery is installed, the EC communicates with the E²PROM in the battery to read information of the newly installed battery.

- ❑ Battery capacity calculation
 - The EC reads battery remaining and percentage capacity from the battery through SMBus.

1.6 Batteries

The computer has two types of battery:

- Main battery pack (18650 size)
- RTC battery

The removable main battery pack is the computer's main power source when the AC adaptor is not attached.

The battery specifications are listed in the table below.

Battery name	Material	Output voltage	Capacity
Main battery (4 cell)	Lithium-Ion	14.4 V	2000mAH
Main battery (8 cell)	Lithium-Ion	14.4 V	4300mAH
RTC battery	Lithium	3.3 V	15 mAh

1.6.1 Main Battery

Battery charging is controlled by a power supply microprocessor that is mounted on the system board. The power supply microprocessor controls whether the charge is on or off and detects a full charge when the AC adaptor and battery are attached to the computer. The system charges the battery using quick charge or trickle charge.

Quick Battery Charge

When the AC adaptor is attached, there are two types of quick charge: quick charge when the system is powered off and normal charge when the system is powered on.

The times required for charges are listed in the table below.

Status	Charging time
Normal charge (power on)	12 hours or longer
Quick charge (power off)	About 4 hours or longer

NOTES

1. *The time required for normal charge is affected by the amount of power the system is consuming. Use of the fluorescent lamp and frequent disk access diverts power and lengthens the charge time.*
2. *Using quick charge, the power supply microprocessor automatically stops the charge after eight hours regardless of the condition of the battery. Overcharging could cause the battery to explode.*

If any of the following occurs, the battery quick charge process stops.

1. The battery becomes fully charged.
2. The AC adaptor or battery is removed.
3. The battery or output voltage is abnormal.
4. The battery temperature is abnormal.
5. The battery SMBus communication fails.
6. The battery cell is bad.

Detection of full charge

A full charge is detected from the battery pack through SMBus when the battery is charging.

1.6.2 RTC battery

The RTC battery provides power to keep the current date, time and other setup information in memory while the computer is turned off. The table below lists the charging time and data preservation period of the RTC battery. The RTC battery is charged by the adaptor or main battery, while the computer is powered on.

Status	Time
Charging Time (power on)	About 24 hours
Data preservation period (full charge)	1 month

Chapter 3

Tests and Diagnostics

Contents

3.1	The Diagnostic Test	3-3
3.2	Executing the Diagnostic Test.....	3-4
3.3	Config Check Test.....	3-8
3.4	DMI Check Test	3-9
3.5	Speaker Audio Test	3-10
3.6	Fan ON/OFF Test.....	3-12
3.7	Main Battery Charge Test	3-13
3.8	FDD Test	3-14
3.9	CD-ROM Test	3-15
3.10	Keyboard Test	3-16
3.11	Mouse (Pad) Test	3-19
3.12	LCD Pixels Mode Test	3-21
3.13	Lid Switch Test	3-22
3.14	HDD R/W Test.....	3-23
3.15	LAN Test.....	3-25
3.16	RTC Test	3-27
3.17	CD Control Button Test	3-28

The Diagnostic Test

This chapter explains how to use the Test & Diagnostic program to test the functions of the **(Base on Sakhir10E T&D version 1.0)** hardware modules. The Test & Diagnostic Program is stored on the T&D diskettes. The program consists of a series of tests that run automatically when the Diagnostics Program items are selected and executed.

NOTES: *To start the diagnostics, follow these steps*

1. *Check all cables for loose connections.*
2. *Exit this program when you are at Main Menu.*

The TEST & DIAGNOSTIC PROGRAM contains the following functional tests:

- CONFIG CHECK TEST
- DMI CHECK TEST
- SPEAKER AUDIO TEST
- FAN ON/OFF TEST
- MAIN BATTERY CHARGE TEST
- FDD TEST
- CD-ROM TEST
- KEYBOARD TEST
- MOUSE(PAD) TEST
- LCD PIXELS MODE TEST
- MAGNETIC SWITCH TEST
- HDD R/W TEST
- LAN TEST
- RTC TEST
- Button Test

You will need the following equipment to perform some of the Diagnostic test programs.

- The diagnostics diskette (2 pcs)
- A formatted working diskette for the floppy disk drive test (Floppy Disk Drive Test)
- A data CD disc (CD-ROM Test)
- A LAN loopback connector (LAN Test)

The following sections explain how to execute the Test & Diagnostic Program and detail the tests within the program.

3.1 Executing the Diagnostic Test

Toshiba MS-DOS is required to run the DIAGNOSTICS PROGRAM. To start the DIAGNOSTIC PROGRAM, follow these steps:

1. Insert the diagnostics diskette #1 in the floppy disk drive and turn on the computer. (The diagnostics diskette contains the MS-DOS boot files.) And then follow the instructions to swap with the diagnostics diskette #2 for T&D program installed in RAM driver.

NOTE: To execute the CD test, make sure the CD is installed in the ODD drive.

The T&D Program can run by single test item when you press corresponsive English letter of test item, or run two or more test items what you like if you choose them by “Arrow cursors” and “Space Bar” – the wonderful thing is you can setup test loop by “Enter” button. And it also asks you if you like to copy test log file to diskette as reference at the end of test(s).

The test list is as the following:

- A. CONFIG CHECK TEST
- B. DMI CHECK TEST
- C. RTC TEST
- D. LAN TEST
- E. SPEAKER AUDIO TEST
- F. FAN ON/OFF TEST
- G. MAIN BATTERY CHARGE TEST
- H. FDD TEST
- I. CD-ROM TEST
- J. KEYBOARD TEST
- K. MOUSE (PAD) TEST
- L. LCD PIXELS MODE TEST
- M. MAGNETIC SWITCH TEST
- N. HDD R/W TEST
- O: Button test

The below display will show up at the beginning of T&D program

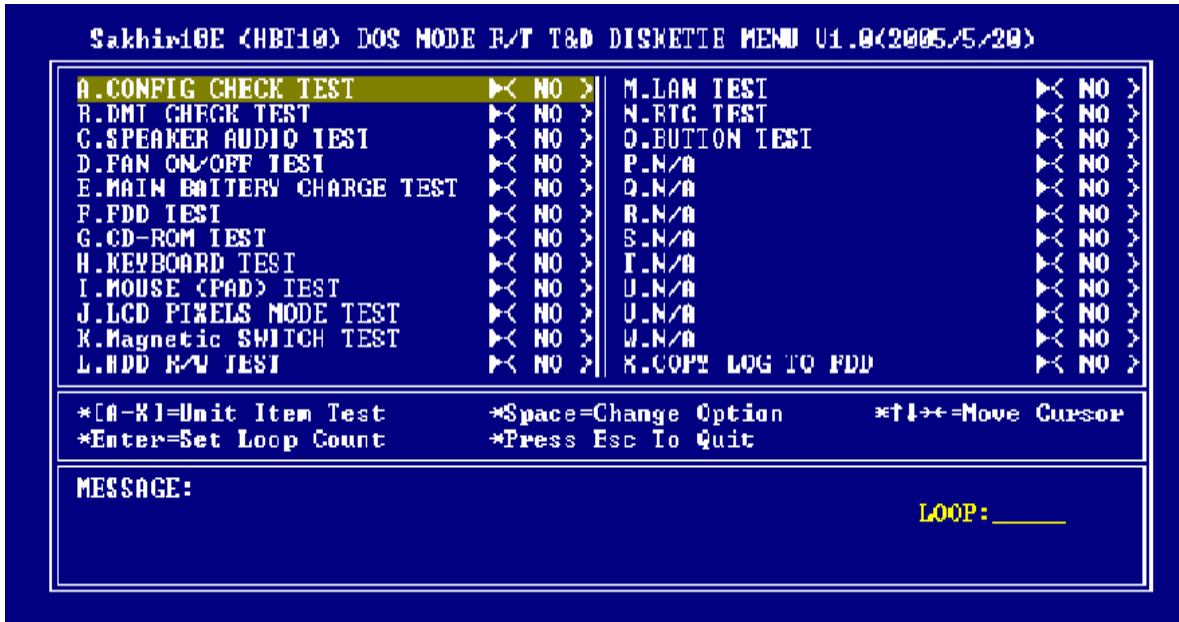

If the test result passes, the following display will show up:



If an error is detected and a test fails, the following message displays:



Then press any key for next actions – the below display presented if copying test log file onto diskette is necessary. This action will be executed when “Y” key pressed.

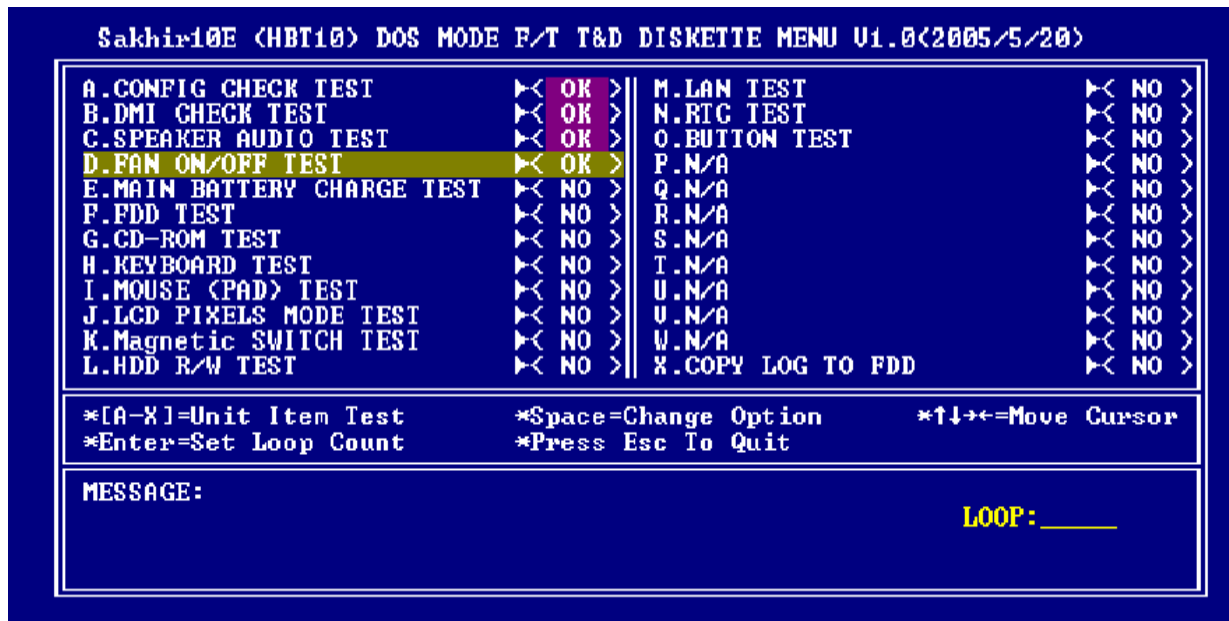

It will skip this process if “N” key pressed.

And then it will check if it’s necessary to leave this program. Program will quit when “Y” key pressed and it will go back main menu for next test if “N” key pressed.

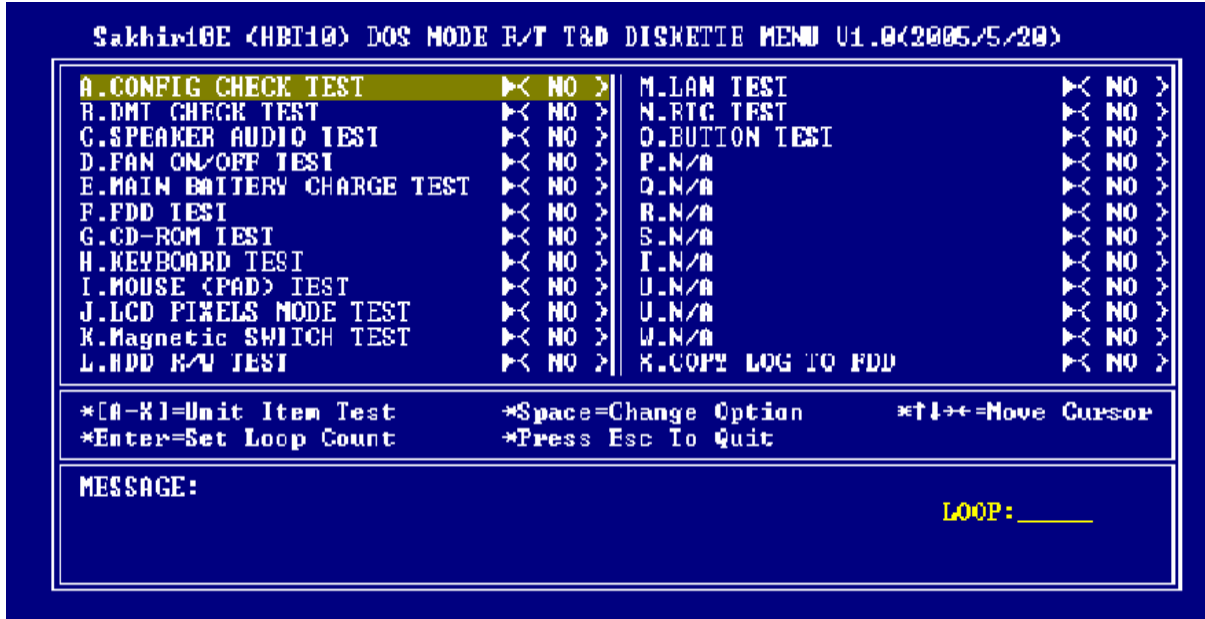

NOTE: Press **Pause** to pause a test and **Enter** to resume.

3.2 Config Check Test

The config check test checks unit configuration. It includes:

- ◆ CPU type (P4/CEL; Dothan; Cache ; CPU speed)
- ◆ BIOS version
- ◆ Panel ID
- ◆ VRAM size
- ◆ System memory size (*** MB)
- ◆ ODD type (DVD-SuperMulti; COMBO; ...)
- ◆ HDD type & capacity (Vendor ID. Model .Firmwave)
- ◆ Wireless type
- ◆ LAN Type (LAN10/100; GigaLAN)
- ◆ With/Without Bluetooth (BLUE/NONE)
- ◆ FIR
- ◆ Battery cell

This test needs input unit Part Number by manual to make comparison with known SKU data.

NOTE: To execute this test, you must input unit **Part Number** as “Uppercase Character”.

Then it will show its configuration is correct (in **green** color) or failed (in **red** color).

The screen should display as below, indicating whether the test is passed or failed after comparison.

```
<Neil Fu> <2002/6/18> <Ver 1.0>
Command Line: cfgchk TabFileName SKU
Example      : cfgchk btw10tab.txt PS110E-0002S-GR

                Please input the SKU: PSP20UFZ000F

CURRENT SPEC IS :
P4800 2800 1.00A ID7 32MB 256 DUDR/RW HDD 60010 MODEM_LAN NoWEP NO_BT FIR 12cell
Press any key to continue . . .
```

3.3 DMI Check Test

This test will check if the computer's Desktop Management Interface (DMI) is correct.

DMI includes:

- ◆ Manufacturer
- ◆ Production Name
- ◆ Version
- ◆ Serial Number
- ◆ UUID
- ◆ OEM String

It needs to input unit Part Number by manual, then show this unit DMI information and makes comparison with SKU data.

NOTE: To execute this test, you must input unit **Part Number** as “**Uppercase Character**”.

The screen should display as below, indicating whether the test is passed or failed after comparison.



3.4 speaker Audio Test

The speaker audio test allows the user to aurally confirm the speaker functions. And check both speakers if they are OK within 3 times “Beep” sound generated.

NOTE: Remember to tune up the volume as “*Maximum*” before this test starts.

The screen should display as below, indicating whether the test is passed or failed after the question.

```
=====Speaker audio Test=====
```

1. Please adjust volume to max level.
2. Please listen to both of speaker will send out Beep sound (3 times).

```
Press any key to continue . . .
```

3.5 Fan ON/OFF Test

The fan test allows the user to test aurally whether the fan is working. And follow the below procedures for this test:

- ◆ The computer will let the fan be “ON” after any key pressed. Listen to check whether the fan is working.

NOTE: Remember to approach fan outlet that is near right side of unit whether fan is “ON”.

- ◆ The computer will stop the fan working after any key pressed. Listen to check if the fan is “OFF” – it means no rotating sound.

The screen should display as below, indicating whether the test is passed or failed after the question.

```
===== FAN TEST =====  
  
Please approach FAN outlet to listen to FAN rotating sound.  
  
Press any key to continue . . .
```

3.6 Main Battery Charge Test

NOTE: The AC adaptor (75W, 19V) should be connected to successfully run this test.

This test shows and measures the main battery:

- ◆ Battery type (Lion)
 - ◆ Manufacturer (Sanyo/Panasonic)
 - ◆ Remain charge capacity (0 ~ 100%)
 - ◆ Charge function (PASS/FAIL)
- “Battery Is Full” showed when “remain charge capacity” is 100%

The screen should display as below, indicating whether the test is passed or failed when finished.

```
ONLY FOR 87591 T&D Series Battery Test Program.[591] V1.0 2002/07/23
MAIN Battery

Battery Type: Lion
Manufacturer: Sanyo
Remain charge capacity : 43.7%

Charge Test-> [ PASS ]

Press any key to continue . . .
```

3.7 FDD Test

NOTE: Before running the FDD test, prepare a formatted work diskette (1.44 MB). Remove the diagnostics diskette and insert the work diskette into the FDD. The contents of the floppy diskette maybe erased.

The Floppy Disk Test includes three subtests of the:

1. Sequential seek/verify function (Range: Track 0 ~ 79)
2. Funnel code seek/verify function (Range: Track 0 ~ 79)
3. Write/Read/Compare pattern function (Range: Track 75 ~ 79)

NOTE: The write-protected device of this formatted diskette should be "Disable".

The subtests run automatically.

NOTE: Press "Esc" key can skip the current subtest.

The screen should display as below, indicating whether the subtests pass or fail when finished.

```
***** Fdd Test Program V1.3 *****
Testing Driver A: [1.44 MByte (Cyl:00, Head:2, Sec:18)]...
Testing Seq. seek/verify... Head: 01, Track: 79... [ PASS ]
Testing Fun. seek/verify... Head: 01, Track: 06...
```

3.8 ODD Test

The ODD test allows a user to aurally confirm the CD-ROM functions.

NOTE: A CD disc (including data file) must be inserted into the ODD drive before this test starts.

The CD-ROM test includes two subtests of the:

1. Random read/partial sequential read function
2. Sequential read function (for all surface)

Each item can be chosen by manual. When each test item finished, the CD-ROM tray will open. Check whether the tray can open automatically.

NOTE: Press “Esc” key can skip the current subtest.

The screen should display as below, indicating whether the subtests pass or fail when finished.

```
CDROM Utility (for Testing only) Ver 1.0
-----
Testing CDROM Information ..... Press [ESC] key to skip testing
-----
CD ROM Drive Z:, MSCDEX ver.: 2.23, Driver name: TSYCD1 , Vol.: 020329_1105
Total 198960 sectors(2352 bytes/sector) = 467953920 bytes
Testing CD ROM reset function...

Partial sequential read ..... 198950
Random read ..... 95496 PASS

Please remove CD Media, then close CD tray ...

Press any key to continue . . .
```

3.9 Keyboard Test

The keyboard test checks the all keys function.

NOTE: *The Num Lock and the Overlay mode must be off to execute the keyboard test.*

Before keyboard test starts, the keyboard matrix code should be chosen as below display:

1. **K** (UK, for Europe)
2. **S** (US, for America)
3. **J** (JP, for Japan)

When you execute this test, the keyboard layout is drawn on the display. When any key is pressed, the corresponding key on the screen changes to black as shown below.

It will indicate whether the subtest is passed or failed after the question.

NOTE: *The “Fn” key cannot be tested in the keyboard test. To determine whether the “Fn” key is working correctly, press “Fn+F6 ” or “Fn+F7 ” keys to check if LCD display brightness change gradually.*

Version: 1.80

Keyboard pad sequential test: Compal 86 key UK matrix ◀ 38

ESC	F1	F2	F3	F4	F5	F6	F7	F8	F9	F10	F11	F12	PSC	PAU	WIN	PRN	
1	2	3	4	5	6	7	8	9	0	-	=	BCK	HME				
TAB	Q	W	E	R	T	Y	U	I	O	P	[]	\	PGU			
CAL	A	S	D	F	G	H	J	K	L	;	'	ENT	PGD				
LS	Z	X	C	V	B	N	M	,	.	/	RS		END				
CTR	FN	ALT	'	SPC				<	INS	DEL	ALT		↑				

Press <Fn+Up> and <Fn+Down> key.
<Ctrl-Break> Quit

Version: 1.80

Keyboard pad sequential test: Compal 85 Key US matrix ◀ 10

ESC	F1	F2	F3	F4	F5	F6	F7	F8	F9	F10	F11	F12	PSC	PAU	WIN	PRN	
1	2	3	4	5	6	7	8	9	0	-	=	BCK	HME				
TAB	Q	W	E	R	T	Y	U	I	O	P	[]	\	PGU			
CAL	A	S	D	F	G	H	J	K	L	;	'	ENT	PGD				
LS	Z	X	C	V	B	N	M	,	.	/	RS		END				
CTR	FN	ALT	'	SPC					INS	DEL	ALT		↑				

Press <Fn+Up> and <Fn+Down> key.
<Ctrl-Break> Quit



9

Pressing a key also reveals that key's **scan codes** in the upper right hand corner of the screen. When the key is depressed, its **make code** is displayed. When the key is released, the **break code** is shown.

3.10 Mouse (Pad) Test

The Mouse test allows the user to select and assign values to the following, using the Touch Pad or “**Tab**” key to move between selections:

1. Mouse Speed (on a scale from slow to fast)
2. Acceleration (Off, Low, Medium, High)
3. Button Assignments (Left + Right / Right button, either Unassigned or Drag Lock)
4. Swap Buttons (Left /Right)

NOTE: The Touch Pad test cannot be used to test an external USB mouse.

The Touch Pad button subtest allows users to test their Touch Pad buttons. If the buttons are clicked, the cursors should appear in the corresponding box of the button figure that is displayed on the screen as below.



After checking T/Pad buttons and cursor's function, use "Tab" key or use T/Pad cursor to click the "OK" column will end this test.

It will indicate whether the subtests pass or fail after three questions.

NOTE: *The above figure has three compartments although the Touch Pad installed may only have two buttons. In this case, the central compartment in the figure does not correspond to any button.*

3.11 LCD Pixels Mode Test

This LCD pixels mode test checks whether video display is fine.

This test includes two modes of the test:

1. Text Mode
 - including 40*25 (16 colors) and 80*25 (2/16colors).
2. VGA Mode
 - including 320*200 (4/16/256 colors), 640*200 (2/16 colors), 640*350 (2/16 colors), 640*480 (2/16/256 colors), 800*600 (256 colors) and 1024*768 (256 colors).

The screen should display as below, indicating whether the test is passed or failed after the question.

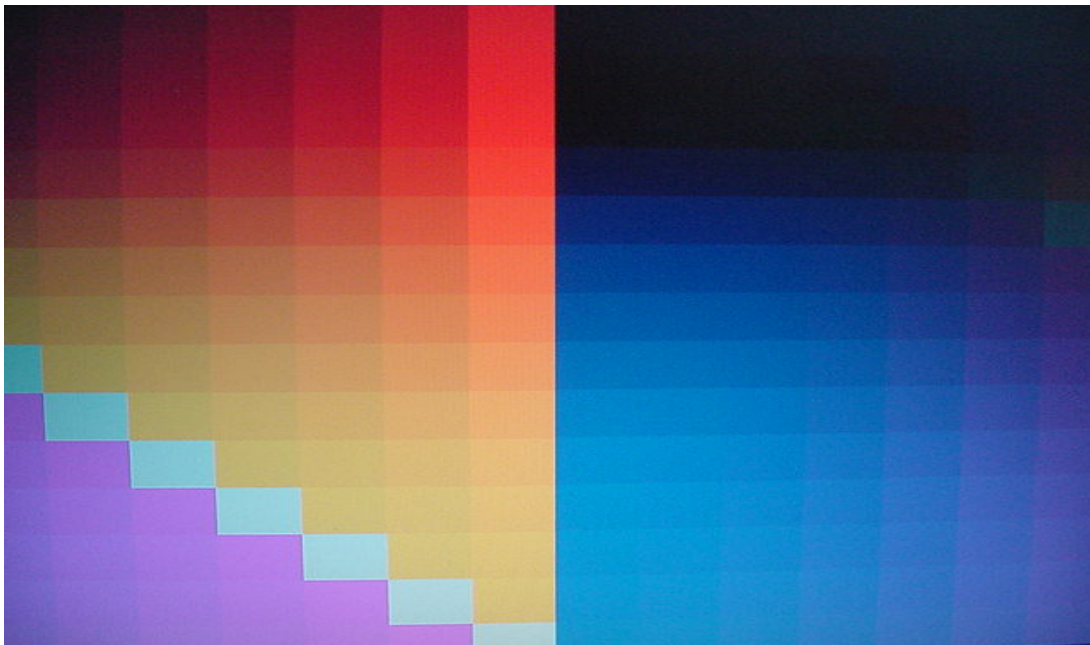

3.12 Magnetic Lid Switch Test

The lid switch test checks the lid function of the unit. When LCD cover closed, the lid should enable to turn off the display.

NOTE: Remember to tune up the volume as “**Maximum**” before this test starts.

Follow below steps to run this test:

1. Close the LCD cover.
2. Heard 3 “Beep” sound happened during LCD closed.
3. Open the LCD.

Then it will indicate whether the test is passed or failed.

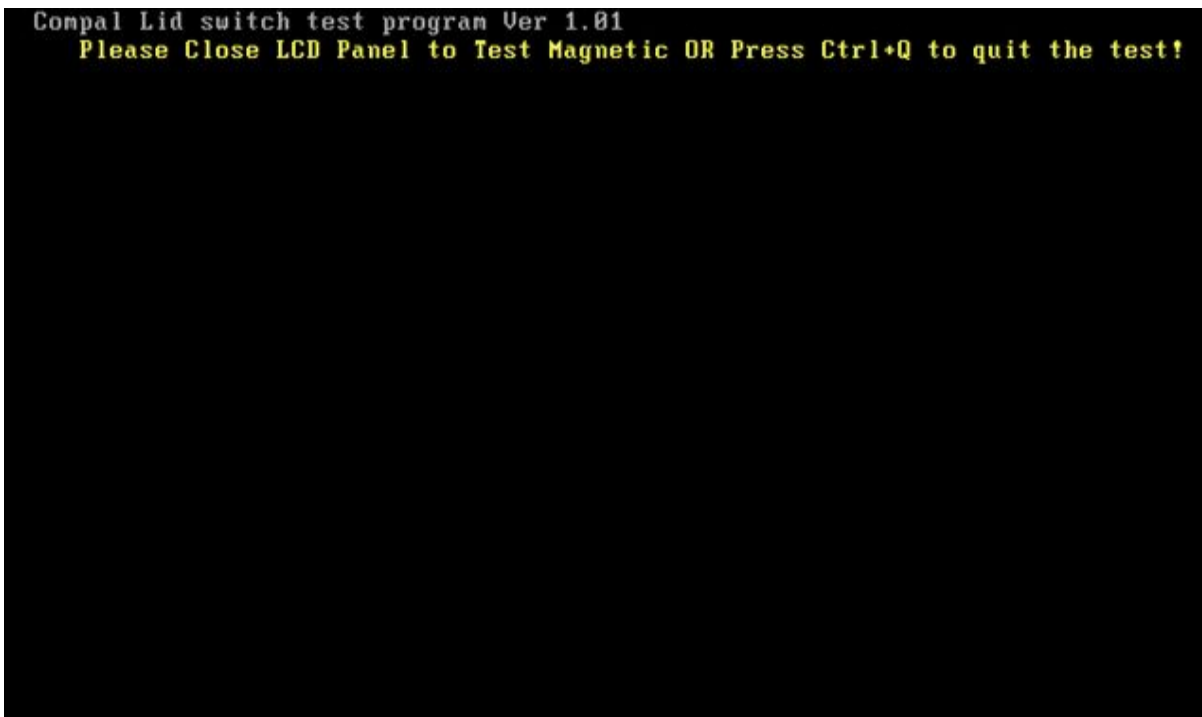
A screenshot of a terminal window showing the 'Compal Lid switch test program Ver 1.01'. The text is displayed in a yellow monospaced font on a black background. The first line reads 'Compal Lid switch test program Ver 1.01' and the second line reads 'Please Close LCD Panel to Test Magnetic OR Press Ctrl+Q to quit the test!'.

```
Compal Lid switch test program Ver 1.01
Please Close LCD Panel to Test Magnetic OR Press Ctrl+Q to quit the test!
```

3.13 HDD R/W Test

The HDD R/W test allows the user to test aurally HDD read/write function. For data security concern, it is necessary to input password - “**hard disk**” before HDD write test starts.

The HDD test includes three subtests of the:

1. Sequential read (all surface)
2. Sequential write (all surface)
3. Partial W/R + Random W/R

After the choice is made, HDD information will show as below:

- ◆ Model name
- ◆ Firmware revision
- ◆ Serial number
- ◆ CHR (Cylinder High Register) mode – including cylinders, heads, sectors and sizes.
- ◆ LBA (Logical Block Addressing) mode – including sectors and sizes.
- ◆ Support Ultra DMA Mode

```

HDD Utility (for Testing only) Ver 1.0
-----
Testing HDD Information ..... Press Ctrl+Break keys to stop testing
-----
Model name           = IC25N030ATCS04-0
Firmware revision    = CA30A71A
Serial number        =          CSL304D5CARPWA
CHR Mode cylinders   = 16383
CHR Mode heads       = 16
CHR Mode sectors     = 63
CHR Mode sizes       = 8063 MB
LBA Mode sectors     = 58605120
LBA Mode sizes       = 28615 MB
Support Ultra DMA Mode = 3f
Support PIO Mode     = 1f
-----

Begin Testing ..... Sequential read (all surface)
--> Testing of Sectors = 13300947

```

NOTE: Press “**Ctrl + Break**” keys can terminate the current subtest.

The screen should display as previous picture, indicating whether the subtest is passed or failed when finished.

NOTE: The AC adaptor should be connected to successfully run this test.

3.14 LAN Test

The LAN test checks the LAN full-duplex environment.

NOTE: LAN loopback needs to plug in before test begins.

And LAN information will show on the test screen:

- ◆ IO Base – Port: 3000H
- ◆ IRQ – AH, it's "IRQ 10".
- ◆ Node – it is "MAC Address".
- ◆ Line Frame – 1514 Bytes.
- ◆ Line Speed – 100Mbps or 10 Mbps.
- ◆ Bus ID – it's "4".

The LAN test includes two subtests of the:

1. Speed100
 - including Ethernet_802.2, Ethernet_II, Ethernet_SNAP and Ethernet_802.3. All test items are in LSB mode.
2. Speed10
 - including Ethernet_802.2 in LSB mode.

The subtests run automatically.

The screen should display as below, indicating whether the subtests pass or fail when finished.

```
2.N_May_Test=false           none
3.Boot_Rom=false            none
4.Speed100=true             testing
5.Speed10=true              testing

                                     Press any key to exit

Realtek RTL8139(A/B) Fast Ethernet MLID v3.62 (000112)
(c) Copyright 1999, by Realtek Semiconductor Corp. All rights reserved

Full duplex environment,  IRQ 10, Port 3000, Node Address 23F7993AA L
Max Frame 1514 bytes, Line Speed 100 Mbps, Bus ID 4
Board 1, Frame ETHERNET_802.2, LSB Mode
Board 2, Frame ETHERNET_II, LSB Mode
Board 3, Frame ETHERNET_SNAP, LSB Mode
Board 4, Frame ETHERNET_802.3, LSB Mode
```

If an error is detected and a test fails, the following message displays:

```
F A I L

Press any key to continue . . .
```

3.15 RTC Test

Checks the computer's RTC (Real Time Clock) and calendar functions by comparing the DOS and CMOS values.

The test runs automatically.

The screen should display as below, indicating whether the test is passed or failed when finished.

```
====RTC TEST====

Please Check the result after test.

Press any key to continue . . .

Wait for zero counter..
Testing...
DOS TIME = 22:33:48.04(8122804), CMOS TIME = 22:33:48(8122800)
DOS DATE: 09/19/2002, CMOS DATE: 09/19/2002
DATE & TIME test [ PASS ]

Press any key to continue . . .
```

3.16 CD Control Button Test

The CD control button test allows the user to manually test each of the five CD control buttons. Key "WWW" need to press first. One will hear one "bi" sound when press "WWW" or "Audio" Sound, and continuously "bi" sound for another key test.

The figure below will be displayed:

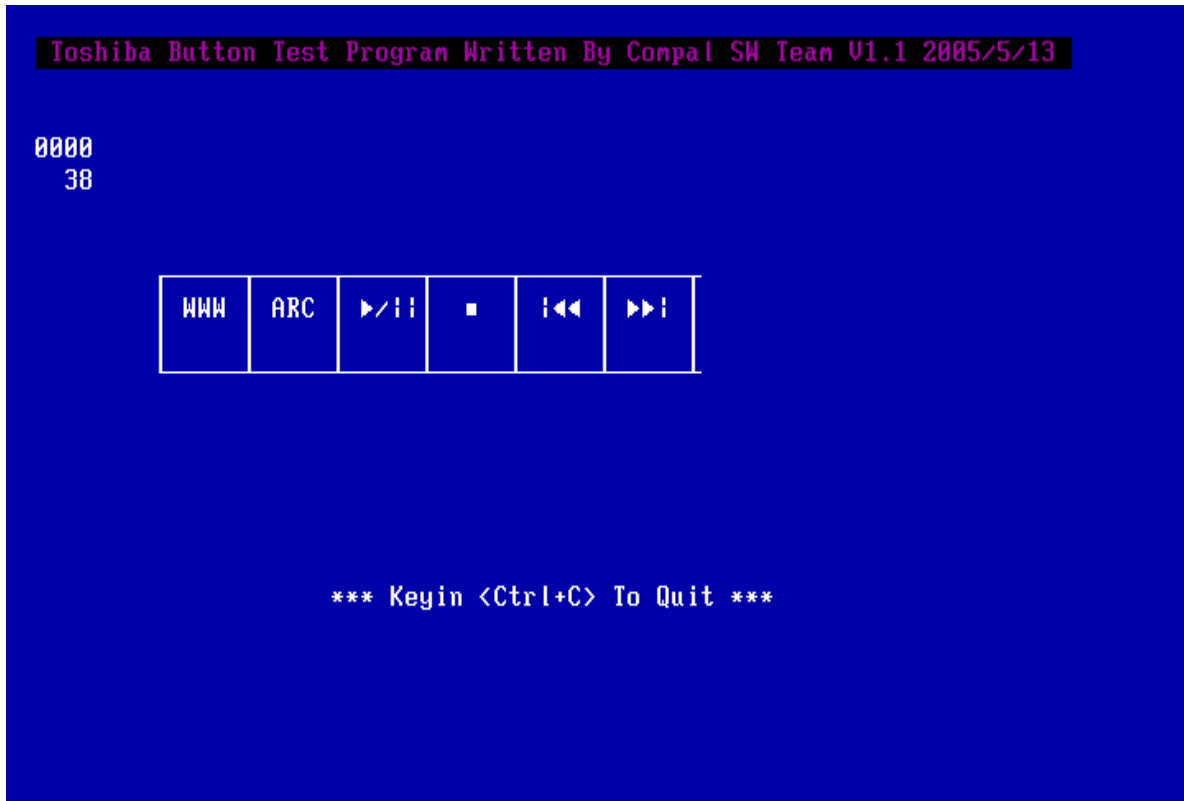

Press each of the buttons on the front panel in turn. A yellow bar will appear on the relevant section of the figure if the button passes the test.

Press **Ctrl +C** to quit the test.

Chapter 4

Replacement Procedures

Chapter 4 Contents

4.1	General.....	4-1
4.2	Battery.....	4-7
4.3	PC Card.....	4-9
4.4	HDD.....	4-11
4.5	Optical Drive Module.....	4-14
4.6	Optical Drive.....	4-15
4.7	Wireless LAN.....	4-16
4.8	Modem.....	4-18
4.9	Expansion Memory Module.....	4-19
4.10	Keyboard.....	4-23
4.11	Display Assembly.....	4-26
4.12	Top Cover.....	4-28
4.13	Direct Play Button Board.....	4-31
4.14	Memory Module.....	4-32
4.15	Touch Pad.....	4-33
4.16	Speakers.....	4-34
4.17	System Board.....	4-35
4.18	Heat Sink, & CPU.....	4-40
4.19	Display Mask.....	4-42
4.20	LCD Module.....	4-43
4.21	FL Inverter Board.....	4-45

Figures

Figure 4-1	Removing the battery pack	4-7
Figure 4-2	Removing a PC Card.....	4-9
Figure 4-3	Installing a PC Card.....	4-10
Figure 4-4	HDD.....	4-11
Figure 4-5	Removing the HDD door	4-11
Figure 4-6	Removing the HDD module	4-12
Figure 4-7	Removing the HDD bracket.....	4-13
Figure 4-8	Removing the optical drive module.....	4-14
Figure 4-9	Removing the optical drive bracket.....	4-15
Figure 4-10	Removing the wireless LAN cover.....	4-16
Figure 4-11	Removing the wireless LAN unit.....	4-17
Figure 4-12	Removing the modem module	4-18
Figure 4-13	Removing the memory module cover	4-19
Figure 4-14	Removing a memory module.....	4-20
Figure 4-15	Removing an expansion memory cover.....	4-21
Figure 4-16	Installing an expansion memory	4-22
Figure 4-17	Removing the strip cover	4-23
Figure 4-18	Removing the keyboard	4-24
Figure 4-19	Disconnecting the keyboard cable	4-25
Figure 4-20	Removing the display assembly screws.....	4-26
Figure 4-21	Removing the wireless and LCD cables	4-27
Figure 4-22	Removing screws of the bottom.....	4-28
Figure 4-23	Removing the top cover	4-29
Figure 4-24	Removing FFC cable	4-29
Figure 4-25	Removing Speaker cables	4-30

Figure 4-26	Removing the Direct Play Button board	4-31
Figure 4-27	Removing the Memory Module	4-32
Figure 4-28	Removing the Touch Pad board	4-33
Figure 4-29	Removing the speakers	4-34
Figure 4-30	Removing LAN board	4-35
Figure 4-31	Removing the fan module.....	4-36
Figure 4-32	Removing USB board.....	4-37
Figure 4-33	Removing the system board	4-38
Figure 4-34	Removing the heat sink	4-40
Figure 4-35	Removing the CPU	4-41
Figure 4-36	Removing the display mask.....	4-42
Figure 4-37	Removing the LCD module-1	4-43
Figure 4-38	Removing the LCD module-2	4-44
Figure 4-39	Removing the FL inverter board	4-45

4.1 General

This chapter explains how to disassemble the computer and replace Field Replaceable Units (FRUs). It may not be necessary to remove all the FRUs in order to replace one. The chart below is a guide to which FRUs need to be removed in order to remove others. Always start by removing the battery pack, next, optional items such as the optional PC Card, then follow the chart downward removing only those FRUs necessary to reach the one you think is causing the computer to operate improperly. Refer to the example on the following page.

Battery pack						
Expansion Memory Module	HDD	ODD	Modem	Keyboard	Wireless LAN	
						Display Assembly
	Top Cover					Display Mask
System Board	Speakers	Memory Module	Touch Pad	Direct Play Button Board	LCD Module	
Fan & Heat Sink					FL Inverter Board	
CPU						

4 Replacement Procedures

The example below shows FRUs to be removed before the CPU can be removed and repaired or replaced. The CPU is overlapped by the top cover which must be removed before the CPU can be reached. The removable HDD, keyboard, wireless LAN, ODD, modem, and display assembly in turn overlap the top cover. Always starts the disassembly process by removing the battery pack.

Battery pack							
Expansion Memory Module	HDD	ODD	Modem	Keyboard	Wireless LAN		
						Display Assembly	
	Top Cover					Display Mask	
System Board		Speakers	Memory Module	Touch Pad	Direct Play Button Board	LCD Module	
Fan & Heat Sink						FL Inverter Board	
CPU							

Safety Precautions

Before you begin disassembly, read the following safety precautions and observe them carefully as you work.

DANGER:

1. *Always use the lithium ion battery pack or backup battery that is authorized by Toshiba or compatible with the unit. Since other battery packs have different specifications, they may be incompatible with the unit, and may burst or explode. Heating or disassembling the battery pack could cause leakage of alkaline solution. Throwing the battery pack into a fire could cause the battery pack to explode.*
2. *The power supply, FL inverter and other components carry high voltages. To avoid the risk of electric shock when you need to turn on the power of a partially disassembled computer to check its operation, be very careful not to touch connectors or components. Also, do not disassemble individual components in first-level maintenance.*

WARNING: To avoid the risk of electric shock or other injury:

1. *Always turn the power off and disconnect the AC adaptor from the power source.*
2. *Remove any metal jewelry or accessories such as necklaces, bracelets, or rings. Batteries in the computer retain an electrical charge so there is danger of electrical shock even when the computer is disconnected from an AC power source.*
3. *Never work with wet or damp hands.*
4. *The computer contains sharp edges and corners: be careful not to injure yourself.*
5. *Make sure that all replacement components meet the specifications for the computer and that all cables and connectors are securely fastened.*

CAUTION: To avoid damage to the computer:

1. *When you change a component, be sure the replacement component meets the required specifications. Never use foreign parts.*
2. *Metal objects such as screws or paper clips which fall into the unit can cause a short-circuit, fire, or other internal damage.*
3. *When assembling the computer, make sure you use the correct screws to secure the various pieces in place. Screw sizes are listed in their corresponding figure. Make sure all screws are securely fastened. Loose screws can cause short circuits, resulting in heat, smoke, or fire.*
4. *Before removing an FRU or other component, make sure all cables to the component have been disconnected.*
5. *If you use AC power, be sure to use the cable that came with the computer or one recommended by Toshiba.*

Before You Begin

Look over the procedures in this section before you begin disassembling the computer. Familiarize yourself with the disassembly and reassembly steps. Begin each procedure by removing the AC adaptor and the battery pack as instructed in section 4.2.

1. Do not disassemble the computer unless it is operating abnormally.
2. Use only the correct and approved tools.
3. Make sure the working environment is free from the following elements whether you are using or storing the computer.
 - Dust and contaminates
 - Static electricity
 - Extreme heat, cold and humidity
4. Make sure the FRU you are replacing is causing the abnormal operation by performing the necessary troubleshooting and diagnostics tests described in chapters 2 and 3 of this manual.
5. Do not perform any operations that are not necessary and use only the described procedures for disassembling and installing FRUs in the computer.
6. After removing parts from the computer, place them in a safe place away from the computer so they will not be damaged and will not interfere with your work.
7. You will remove and replace many screws when you disassemble the computer. When you remove screws, make sure they are placed in a safe place and identified with the correct parts.
8. When assembling the computer make sure you use the correct screws to secure the various pieces. Screw sizes are listed in their corresponding figures.
9. The computer contains many sharp edges and corners, so be careful not to injure yourself.
10. After you have replaced an FRU, make sure the computer is functioning properly by performing the appropriate test on the FRU you have fixed or replaced.

Disassembly Procedures

The computer has two basic types of cable connectors:

- Pressure Plate Connectors
- Standard Pin Connectors

To disconnect a Pressure Plate connector, lift up the tabs on either side of the connector's plastic pressure plate and slide the cable out of the connector. To connect the cable to a Pressure Plate connector, make sure the pressure plate is fully lifted and slide the cable into the connector. Secure the cable in place by pushing the sides of the pressure plate down so the plate is flush with the sides of the connector. Gently pull on the cable to make sure the cable is secure. If you pull out the connector, connect it again making sure the connector's pressure plate is fully lifted when you insert the cable.

Standard pin connectors are used with all other cables. These connectors can be connected and disconnected by simply pulling them apart or pushing them together.

Assembly Procedures

After you have disassembled the computer and fixed or repaired the problem that was causing the computer to operate abnormally, you will need to reassemble the computer.

Install all the removed FRUs following the steps described in the corresponding sections in this chapter.

While assembling the computer, remember the following general points:

- Take your time, making sure you follow the instructions closely. Most problems arise when you get in a hurry assembling the computer.
- Make sure all cables and connectors are securely fastened.
- Before securing the FRU or other parts, make sure that no cables will be pinched by screws or the FRU.
- Check that all latches are closed securely.
- Make sure all the correct screws are used to secure all FRUs. Using the wrong screw can either damage the threads on the screw or the head of the screw and may prevent proper seating of an FRU.

After installing an FRU in the computer, confirm that the FRU and the computer are functioning properly.

Tools and Equipment

The use of Electrostatic Discharge (ESD) equipment is very important for your safety and the safety of those around you. Proper use of these devices will increase the success rate of your repairs and lower the cost for damaged or destroyed parts. The following equipment is necessary to disassemble and reassemble the computer:

- One M2 Phillips screwdriver to remove and replace screws.
- One T5 security screwdriver.
- Tweezers, to lift out screws that you cannot grasp with your fingers.
- ESD mats for the floor and the table you are working on.
- ESD wrist strap or heel grounder.
- Anti-static carpeting or flooring.
- Air-ionizers in highly static sensitive areas.

4.2 Battery

Removing the Battery Pack

To remove the battery pack from the battery bay, follow the steps below.

1. Turn the computer upside down.
2. Disengage the battery pack lock (1).
3. Release the battery pack release latch (2).
4. Remove the battery pack from the bay (3).

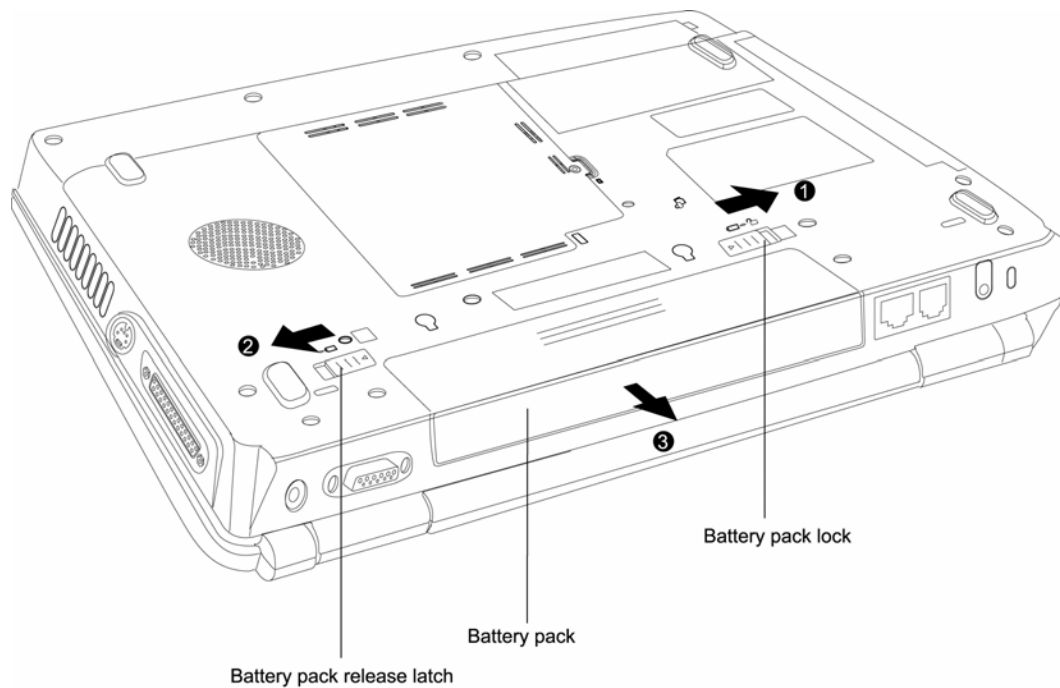

Figure 4-1 Removing the battery pack

NOTE: For environmental reasons, do not throw away a spent battery pack. Please return spent battery packs to Toshiba.

Installing the Battery Pack

To install the battery pack in the battery bay, follow the steps below and refer to the figure in the preceding section.

WARNING: *The battery is a lithium ion battery and can explode if not properly replaced, used, handled or disposed of. Use only batteries recommended by Toshiba as replacements.*

1. Slide the battery pack into the battery bay. The battery bay latch will click automatically.
2. Lock the battery pack lock and battery pack release latch to secure the installation.

4.3 PC Card

Removing a PC Card

To remove a PC Card, follow the steps below.

1. Push the PC Card's eject button. The button pops out when you release it.
2. Push the eject button once more to pop the PC Card out slightly.
3. Grasp the PC Card and remove it.
4. Push the eject button back into place, if necessary.

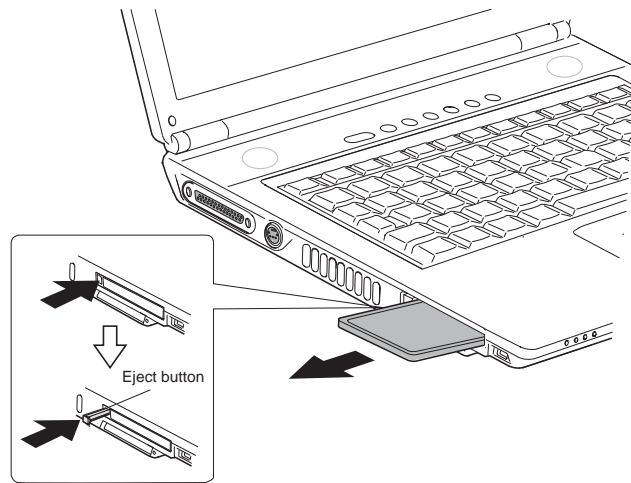

Figure 4-2 Removing a PC Card

Installing a PC Card

To install a PC Card, follow the steps below and refer to the figures in the preceding section.

1. Make sure the eject button does not stick out.
2. Insert a PC Card and press gently to ensure a firm connection.

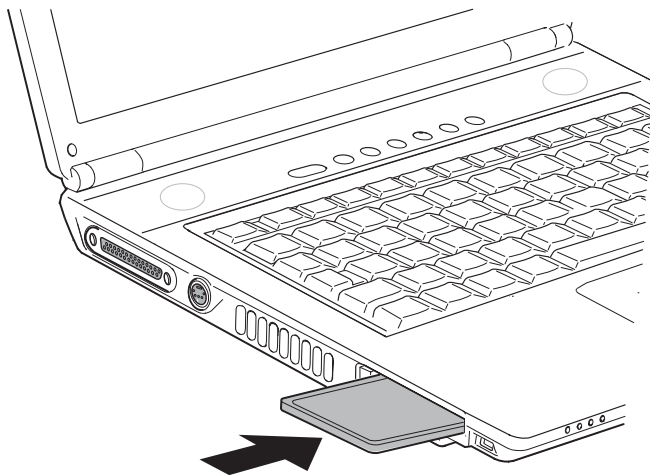

Figure 4-3 Installing a PC Card

4.4 HDD

NOTE: When handling the HDD, do not press the top surface as shown by the arrow. Hold it by the sides.

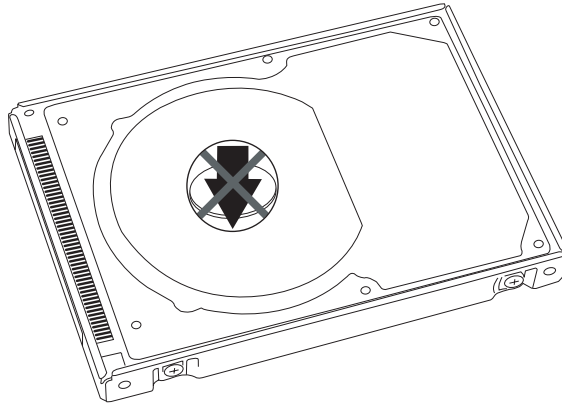

Figure 4-4 HDD

Removing the HDD Module

Follow the steps below to remove HDD module:

1. Turn the computer upside down
2. Remove two black M2.5x5 screws to release the HDD door.

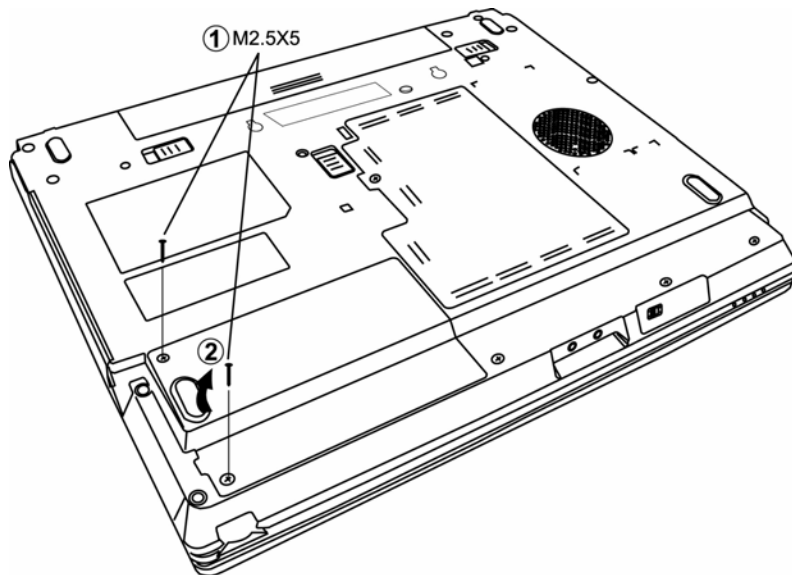

Figure 4-5 Removing the HDD door

3. Pull on the tab to remove the HDD unit.

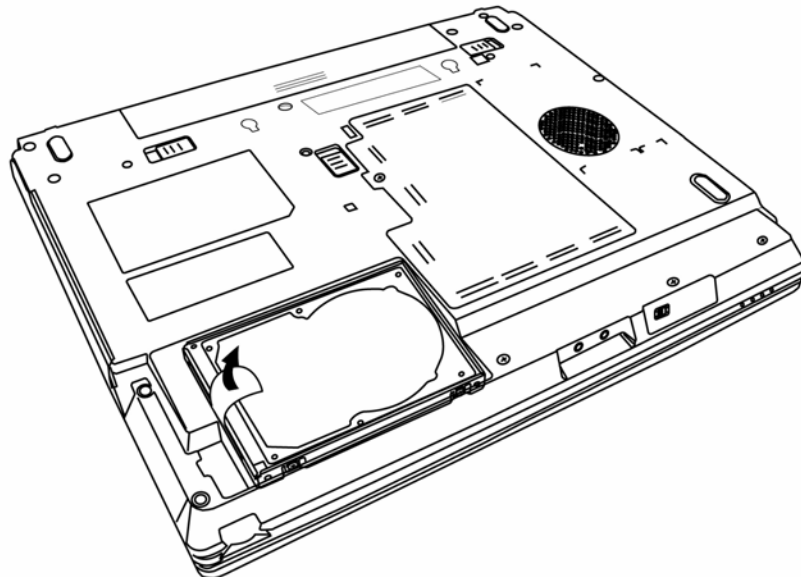

Figure 4-6 Removing the HDD module

4. Remove the HDD from the HDD case.

Installing the HDD Module

To install the HDD module, follow the steps below and refer to the figures in the preceding section.

1. Insert the HDD module into the HDD case.
2. Secure the HDD door with two black M2.5x5 screws.

Disassembling the HDD Module

To take apart the HDD module, first remove it from the computer as described earlier.

1. Remove four M3x3 screws securing the HDD mounting brackets to the HDD. There are two on each side.

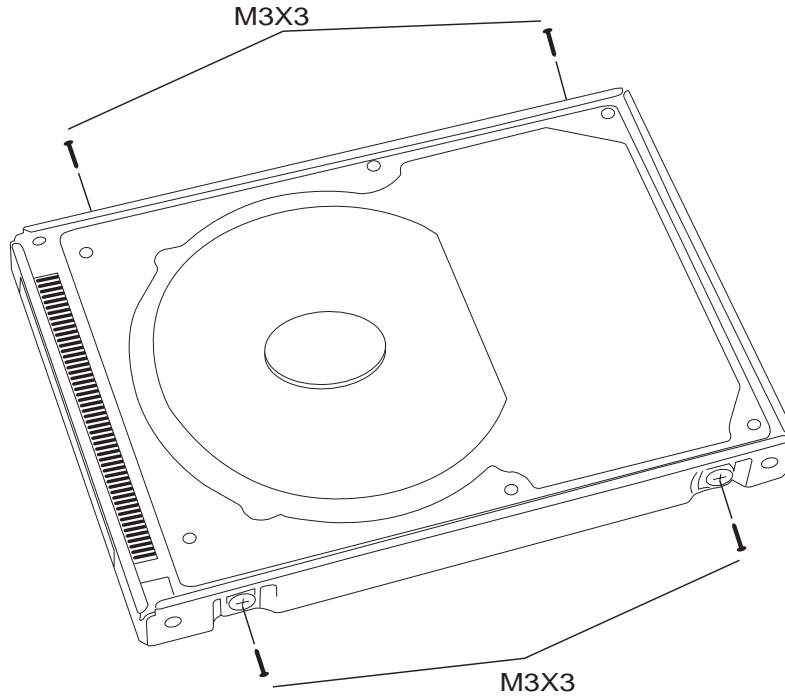

Figure 4-7 Removing the HDD bracket

4.5 Optical Drive Module

Removing the Optical Drive Module

To remove the optical drive module, follow the steps below:

1. Turn the computer upside down.
2. Remove one M2.5x5 screw securing the optical drive module into place.
3. Remove one M2.5x5 screw securing the wireless LAN compartment cover, then open it.
4. Insert your finger into the gap directly behind the ODD then press it gently to eject it slightly from the ODD bay.
5. Slide the optical drive module from the bay.

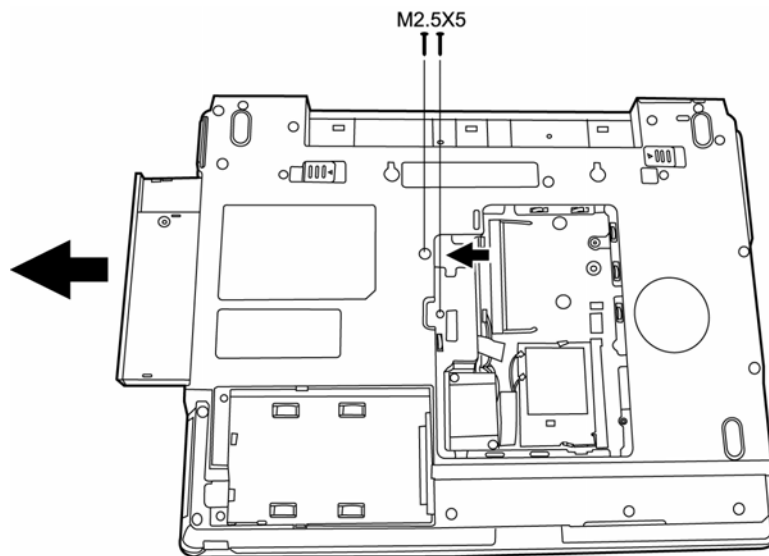

Figure 4-8 Removing the optical drive module

Installing the Optical Drive Module

To install a device in the optical drive module bay, follow the steps below and refer to the figure in the preceding section.

1. Slide the device into the optical drive module bay.
2. Use one M2.5x5 screw to secure it in position.
3. If you previously removed the wireless LAN compartment cover, then secure it in place with one M2.5x5 screw.

4.6 Optical Drive

This computer may be fitted with a:

- CD-RW/DVD-ROM device
- DVD+-R/+-RW
- DVD Super Multi device

Disassembling the Optical Drive

To disassemble the optical drive, then follow the steps below.

1. Remove one M2.5x5 screw and slide the optical drive module from the bay. (*Refer 4.5 Optical Drive Module*)
2. Remove two M2x3 screws from the bracket plate. Remove the bracket plate.

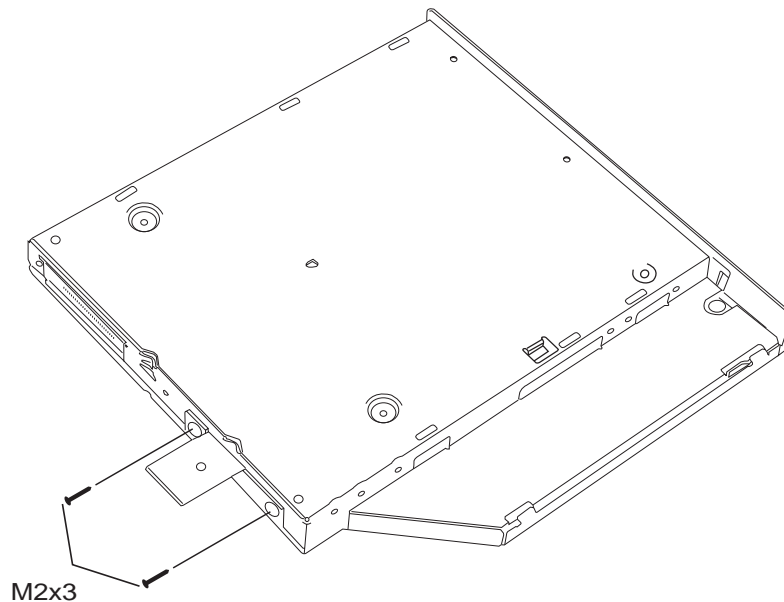

Figure 4-9 Removing the optical drive bracket

Reassembling the Optical Drive

To reassemble an optical drive, follow the steps below and refer to the figure in the preceding section.

1. Position the optical drive bracket plate to the rear panel of optical drive.
2. Secure the optical drive bracket plate with two black M2×3 screws.
3. Install the optical drive module into the bay and secure with one M2.5x5 screw. (*Refer 4.5 Optical Drive Module*)

4.7 Wireless LAN

Removing the Wireless LAN

1. Turn the computer upside down and loosen the embedded M2.5x5 screw securing the wireless LAN compartment cover.

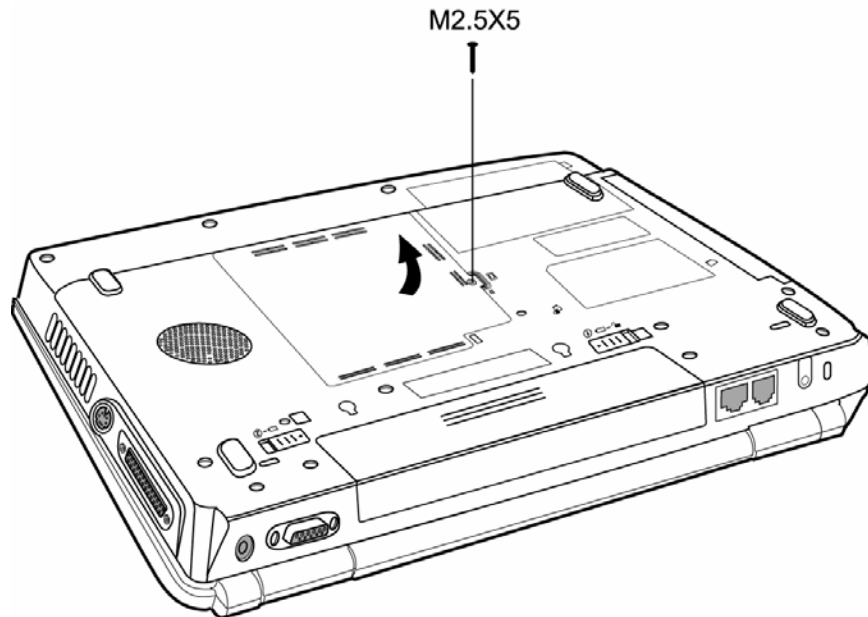

Figure 4-10 Removing the wireless LAN cover

2. Lift off the wireless LAN compartment cover.
3. Remove the embedded one M2.5x3.6 screw securing the Mini PCI bracket.
Note: If your wireless LAN unit is an 'A' type card, then the screw will be a safety screw.
4. Detach the two ends of the wireless LAN antenna.
5. Gently press out on the latches. One end of the wireless LAN unit will pop up.
6. Detach antenna cables from LAN card connector.
7. Grasp the wireless LAN unit and pull it out.

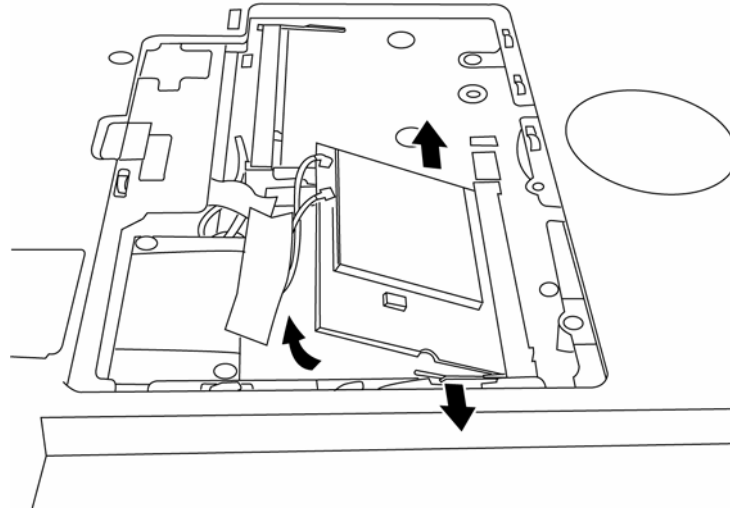

Figure 4-11 Removing the wireless LAN unit

CAUTION: Do not touch the connectors on the wireless LAN unit or on the computer. Debris on the connectors may cause malfunction.

Installing the Wireless LAN

To install the wireless LAN unit, follow the steps below and refer to the figures in the preceding section.

1. Turn the computer upside down and loosen the embedded M2.5x5 screw securing the wireless LAN compartment cover.
2. Lift off the wireless LAN compartment cover.
3. Fit the wireless LAN unit's connector to the computer's connectors and press carefully to ensure firm contact.

CAUTION: Do not touch the connectors on the wireless LAN unit or on the computer. Debris on the connectors may cause malfunction.

4. Gently, push the wireless LAN unit down until the latches engage the unit to hold it in place.
5. Attach the ends of the wireless LAN antenna. Connect the black cable to the AUX connector, and the white cable to the Main connector.
6. Use one M2.5x3.6 screw to secure the Mini PCI bracket.

Note: If your wireless LAN unit is an 'A' type card, then the screw will be a safety screw.

7. Seat the wireless LAN compartment cover and secure it with the embedded security screw.

4.8 Modem

Removing the Modem

To remove the installed modem, remove the Wireless LAN compartment cover and then follow the steps below:

1. Remove two black M2.5x3 screws securing the modem module.
2. Carefully lift the unit off its connector
3. Disconnect the modem cable from the modem module.

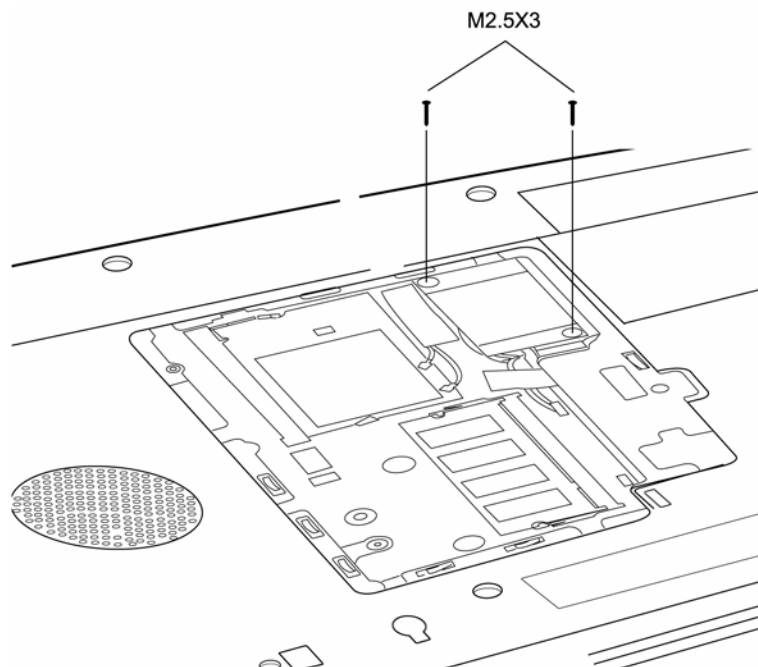

Figure 4-12 Removing the modem module

Installing the Modem

To install a modem, follow the steps below and refer to the figures in the preceding section.

1. Connect the modem cable to the modem module.
2. Fit the modem into its connector and secure it with two black M2.5x3 screws.
3. Restore the Wireless LAN compartment cover and secure it with one M2.5 x 5 screw.

4.9 Expansion Memory Module

Removing an Expansion Memory

To remove an expansion memory module, make sure the computer is in boot mode then:

1. Be sure the power is off and all cables are disconnected from the computer.
2. Turn the computer upside down and remove the battery pack. Loosen the embedded M2.5x5 screw securing the Wireless LAN compartment cover.

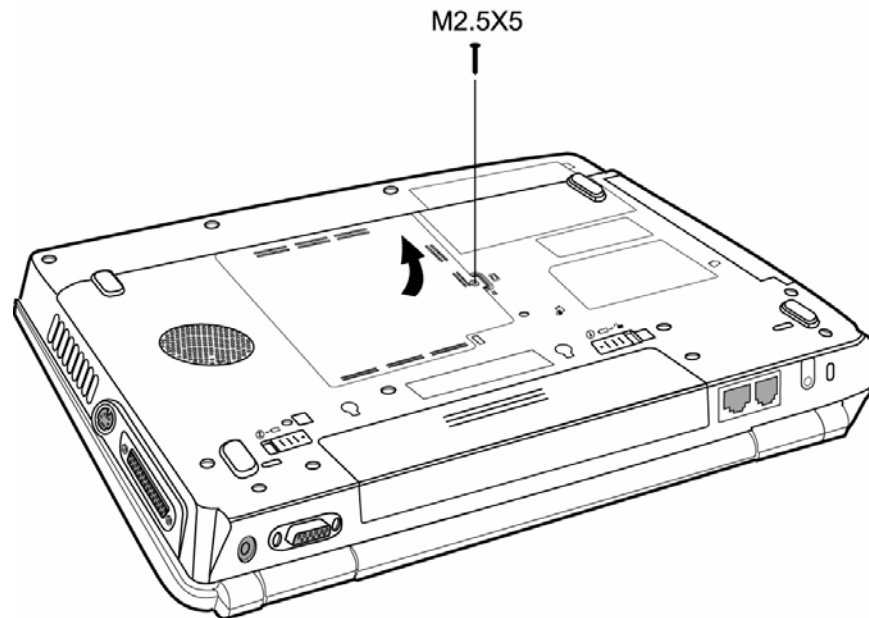

Figure 4-13 Removing the memory module cover

3. Slide your fingernail or a thin object under the cover and lift it off.
4. Push the latches to the outside to release a module. A spring will force one end of the module up.
5. Grasp the module and pull it out.

- 6. Seat the cover and secure its screw.
- 7. Replace the battery pack.

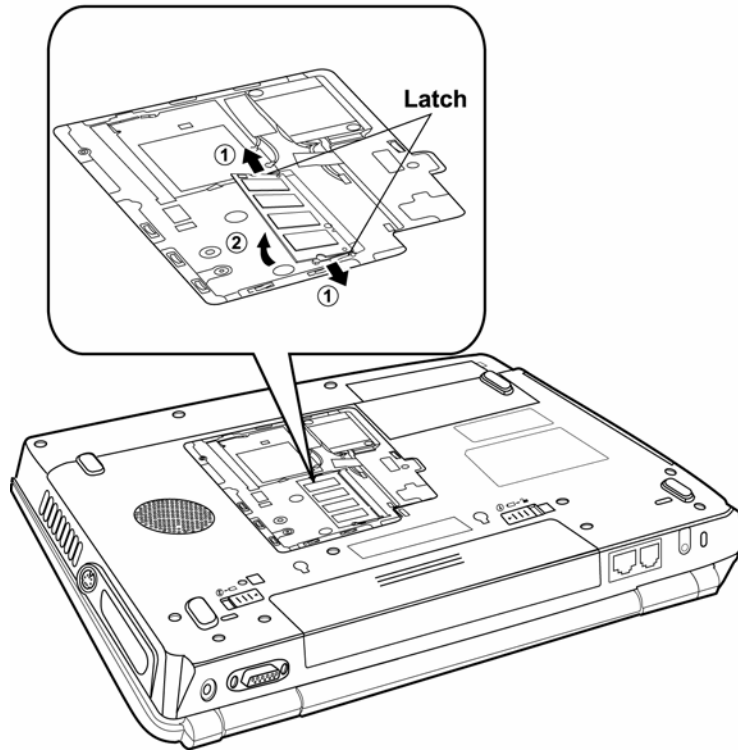

Figure 4-14 Removing a memory module

CAUTION: Do not touch the connectors on the expansion memory or on the computer. Debris on the connectors may cause memory access problems.

Installing an Expansion Memory Module

CAUTION: Do not touch the connectors on the expansion memory or on the computer. Debris on the connectors may cause memory access problems.

Follow these steps to install a memory module:

1. Set the computer to boot mode and turn off the power.
2. Remove all cables connected to the computer.
3. Turn the computer upside down and remove the battery. Loosen the embedded M2.5x5 screw securing the memory module socket cover.

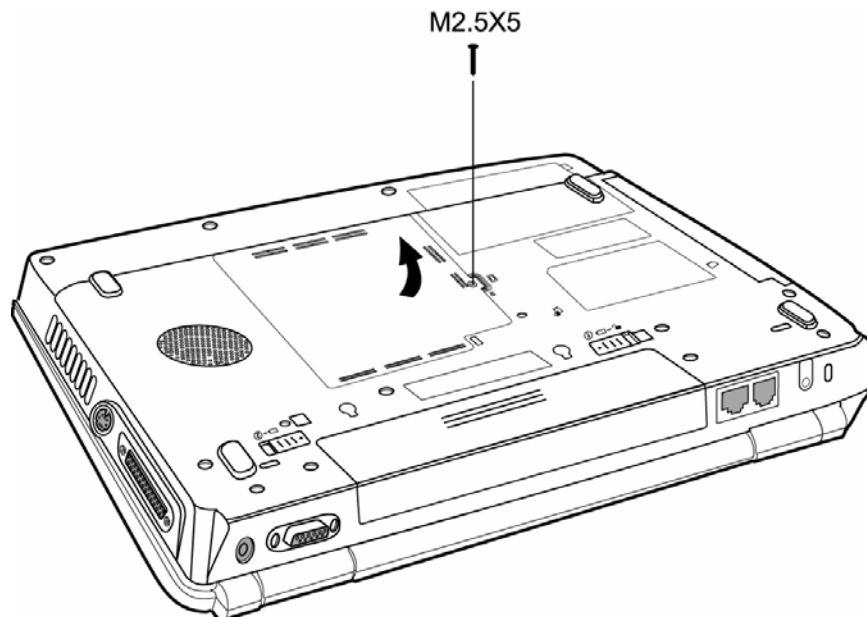

Figure 4-15 Removing an expansion memory cover

4. Slide your fingernail or a thin object under the cover and lift it off.
5. Fit the module's connectors into the computer's connectors at about a 45-degree angle and press the module carefully to ensure a firm connection.

6. Push the module down so it lies flat. Latches on either side will click into place to secure the module.

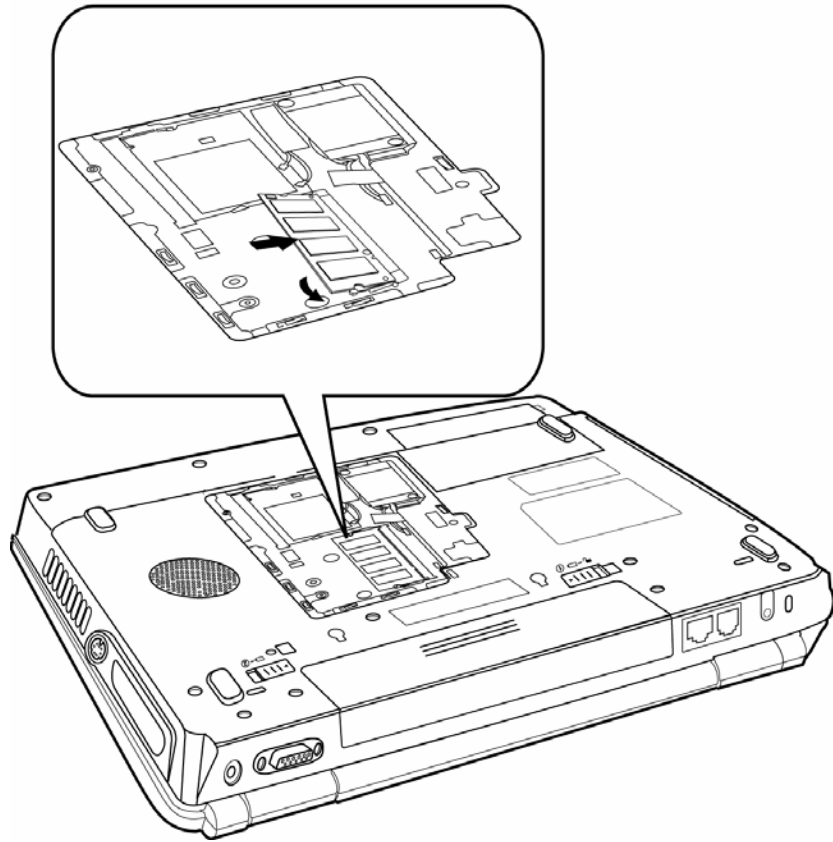

Figure 4-16 Installing an expansion memory

4.10 Keyboard

Removing the Keyboard

Follow the steps below to remove the keyboard:

1. Open the display panel.
2. Remove the strip cover by forcing one end of the strip cover up.

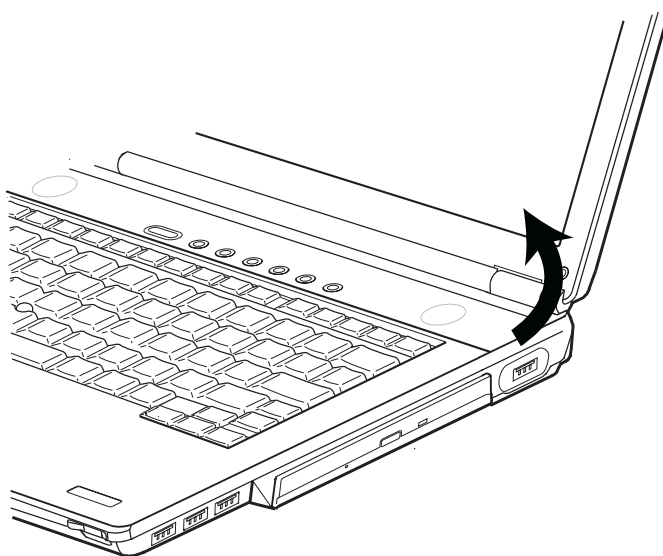

Figure 4-17 Removing the strip cover

3. Remove two black M2.5×3 screws securing the keyboard.

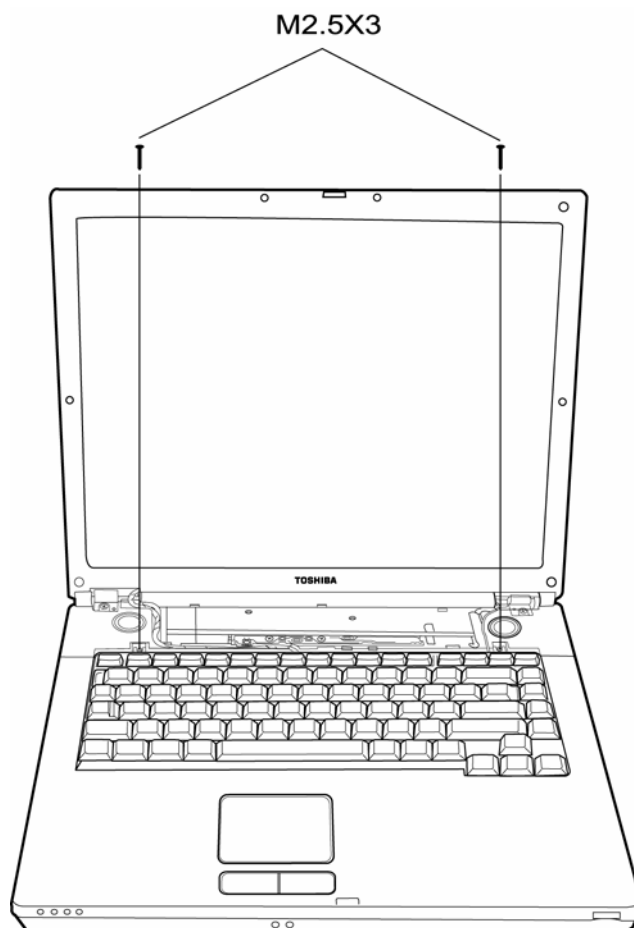

Figure 4-18 Removing the keyboard

4. After removing the screws, flip the keyboard latch with either a screwdriver or a fingernail.
5. Lift the keyboard out of its bay, revealing the keyboard cable.
6. Disconnect the keyboard cable and remove the keyboard from the computer entirely.

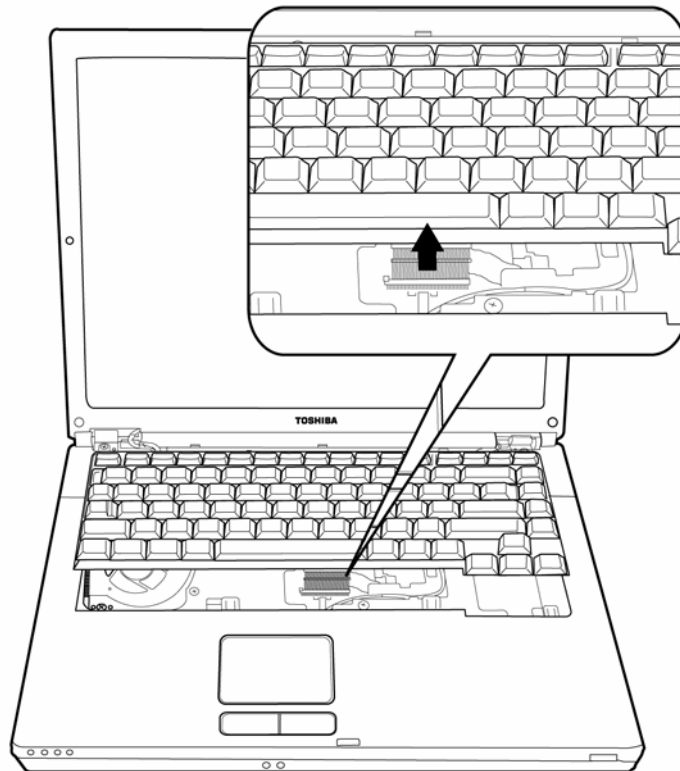

Figure 4-19 Disconnecting the keyboard cable

Installing the Keyboard

To install the keyboard, follow the steps below and refer to the figures in the preceding section.

1. Connect the keyboard cable to the system board.
2. Set the keyboard in place and secure it with two black M2.5x3 screws.
3. Engage the flip latch with either a screwdriver or a fingernail.
4. Set the strip cover and press down to secure the strip cover latches engage.

4.11 Display Assembly

Removing the Display Assembly

To remove the display assembly, first remove the keyboard and wireless LAN, then follow the steps below:

1. Remove two black M2.5x8 screws from the back side of the computer.

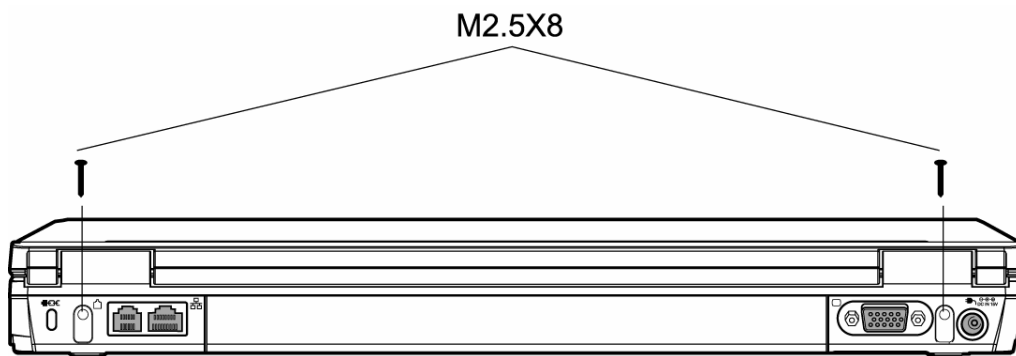

Figure 4-20 Removing the display assembly screws

2. Remove the strip cover.
3. Disconnect the wireless cable (1) from system.
4. Disconnect the LCD cable (2) from system.
5. Remove two M2.5x8 black screws securing LCD hinge.

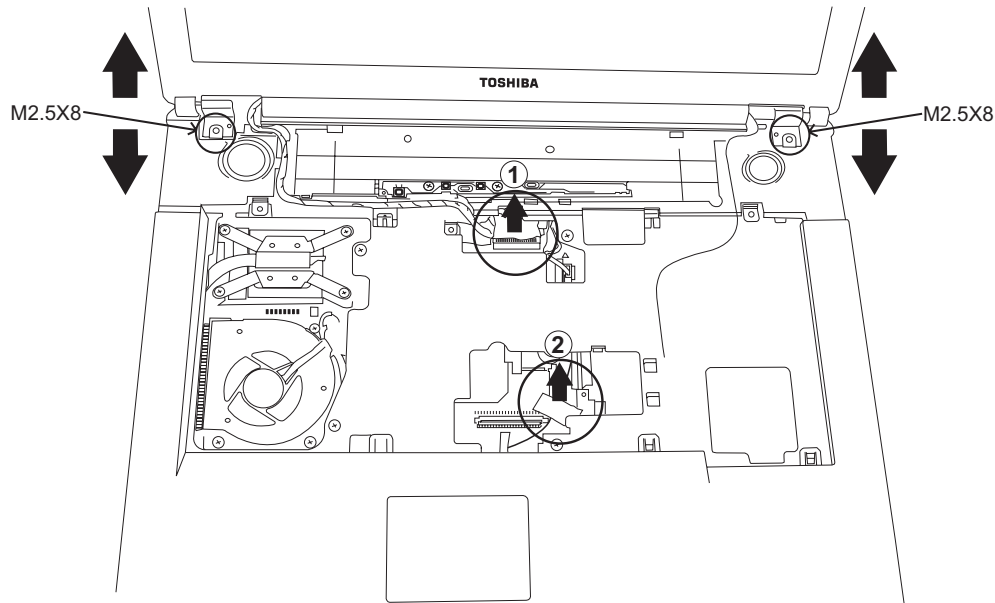

Figure 4-21 Removing the wireless and LCD cables

6. Lift the display assembly from the computer's chassis.

Installing the Display Assembly

To install the display assembly, follow the steps below and refer to the figures in the preceding section.

1. Seat the display assembly taking care not to crush to the LCD cable or wireless cable.
2. Secure two M2.5x8 black screws to LCD hinge.
3. Connect the LCD cable to the top chassis.
4. Connect the wireless cable to the wireless module.
5. Reinstall the strip cover and the keyboard.
6. Secure two black M2.5x8 screws on the back of the computer.

4.12 Top Cover

Removing the Top Cover

To remove the top covers, first remove the battery pack, display assembly, optical drive module, HDD, memory module and wireless LAN as described in the preceding sections, then follow the steps below:

1. Remove seven black M2.5x8 and eight black M2.5x5 securing from bottom.

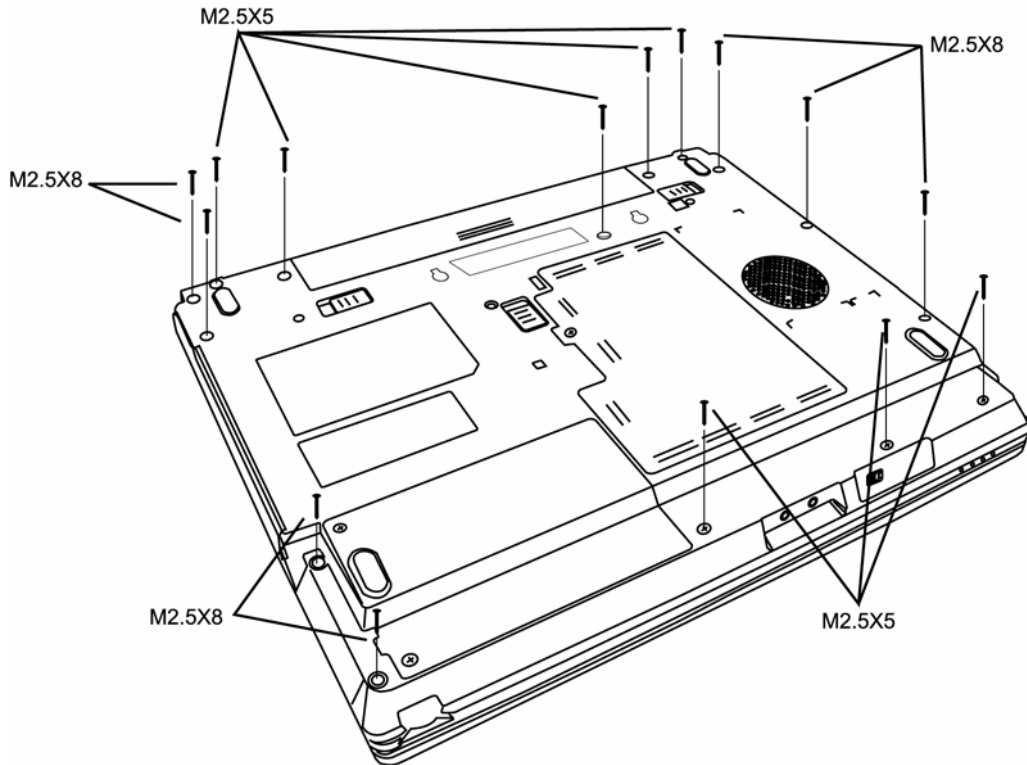

Figure 4-22 Removing screws of the bottom

2. Remove one black M2.5x5 and three black M2.5x14 screws securing the top half of the cover:

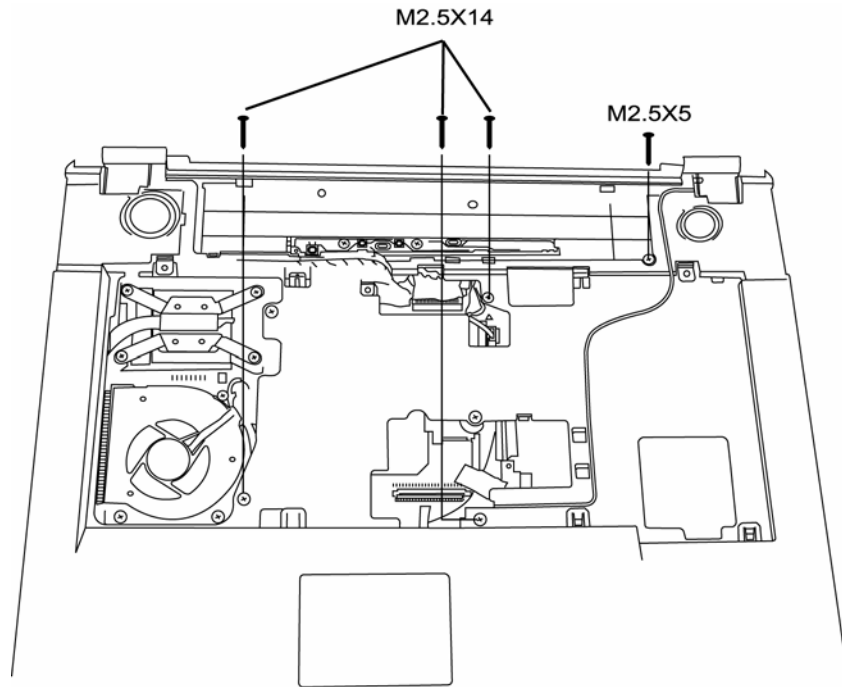

Figure 4-23 Removing the top cover

3. Detach the Touch Pad FFC cable.

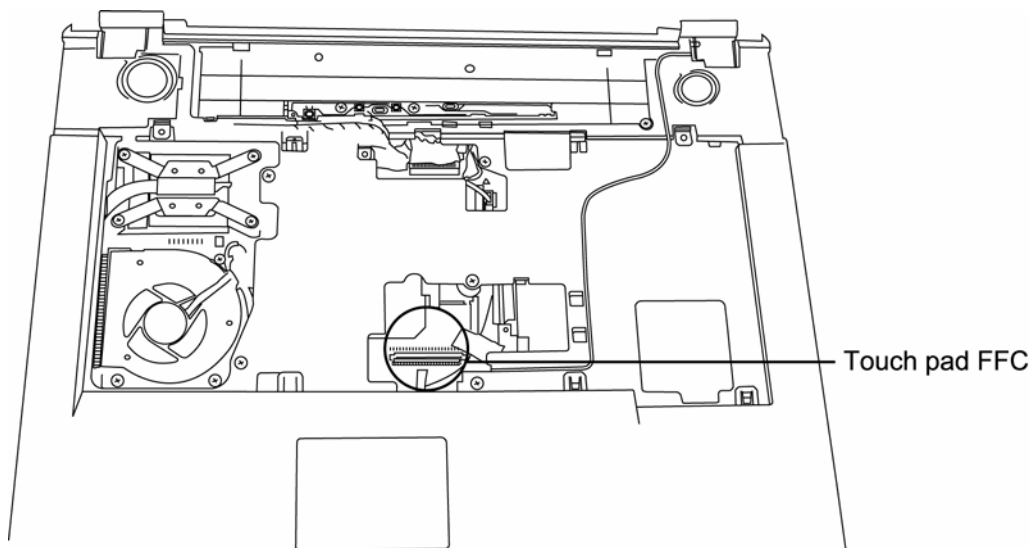

Figure 4-24 Removing FFC cable

4. Detach the speaker cable.

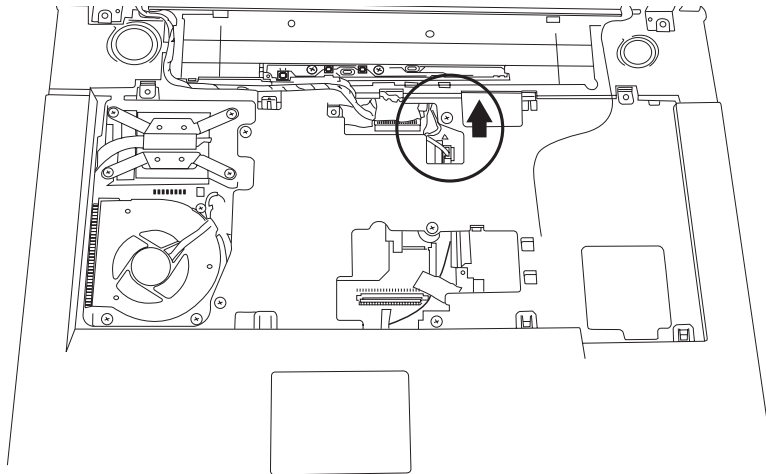

Figure 4-25 Removing Speaker cables

5. Detach the Direct Play Button Board FFC cable.
6. Remove the top cover.

Installing the Top Cover

To install the top cover, follow the steps below and refer to the figures in the preceding section.

1. Seat the top cover and secure the Touch Pad FFC cable.
2. Connect the Direct Play Button Board FFC cable.
3. Connect the speaker cable.
4. Secure the top cover with one black M2.5x5 and three black M2.5x14 screws.
5. Secure the seven black M2.5x8 and eight black M2.5x5 securing from bottom.

4.13 Direct Play Button Board

Removing the Direct Play Button Board

To remove the Direct Play Button board, first remove the Top Cover then follow the steps below:

1. Remove two M2.5x 3 screws and FFC from top cover.

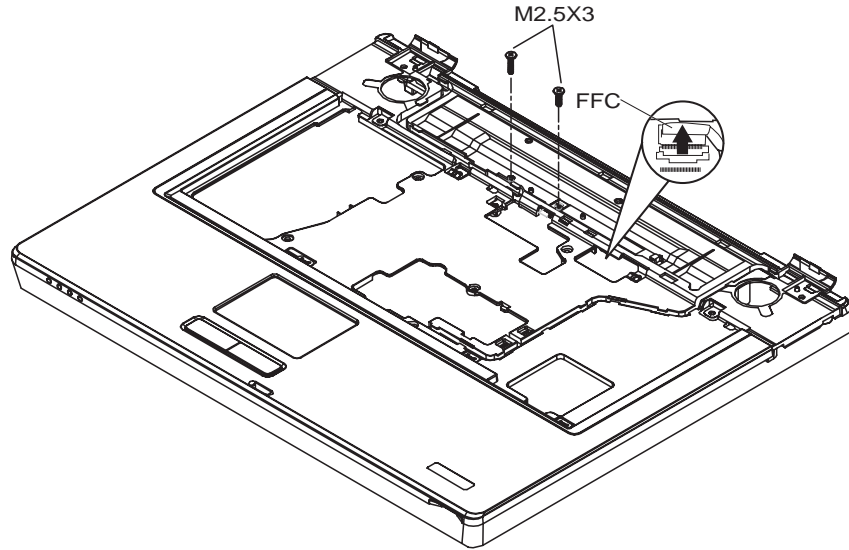

Figure 4-26 Removing the Direct Play Button board

Installing the Direct Play Button Board

To install the Direct Play Button board, follow the steps below and refer to the figures in the preceding section.

1. Secure two M2.5x 3 screws and FFC from top cover.

Appendices

Appendix Contents

Appendix A	Handling the LCD Module.....	A-1
Appendix B	Board Layout.....	B-1
B.1	System Board (FRDSY*) Bottom View.....	B-1
B.2	System Board (FRDSY*) Top View	B-2
Appendix C	Pin Assignments	C-1
C.1	JP23/JP24 SODIMM I/F (200-PIN)	C-1
C.2	JP1/JP2 LCD I/F (22-pin)	C-5
C.3	JP14 RGB I/F (15-pin).....	C-6
C.4	JP10 HDD I/F (44-pin)	C-7
C.5	JP28 ODD Module I/F (60-pin).....	C-8
C.6	JP13 Parallel I/F (25-pin).....	C-9
C.7	JP26 PC Card I/F (84-pin)	C-10
C.8	JP19, JP22 Fan I/F (3-pin)	C-14
C.9	PCN1 AC Adaptor Connector (3-pin)	C-14
C.10	JP29 LINE IN (6-pin)	C-14
C.11	JP30 Microphone (6-pin)	C-15
C.12	JP31 Headphone (6-pin)	C-15
C.13	JP31 Headphone Connector (6-pin).....	C-15
C.14	JP29 LINE-IN Connector (6-pin)	C-15
Appendix D	Keyboard Scan/Character Codes	D-1
Appendix E	Key Layout	E-1
E.1	Japanese (JA) Keyboard	E-2
Appendix F	Series Screw Torque List.....	F-1
Appendix G	Reliability.....	G-1

Figures

Figure B-1 System board (FRDSY*) layout (Bottom)..... B-1

Figure B.2 System board (FRDSY*) layout (Top) B-2

Figure E-1 US keyboard E-1

Figure E-2 UK keyboard E-1

Figure E-3 SP keyboard..... E-2

Figure E-4 JA keyboard..... E-2

Figure E-5 KO keyboard E-3

Figure E-6 CF keyboard E-3

Figure E-7 Portuguese-ALPS keyboard E-4

Figure E-8 US-INTE_ALPS Keyboard..... E-4

Figure E-9 GR keyboard..... E-5

Figure E-10 FR keyboard E-5

Figure E-11 CH keyboard..... E-6

Figure E-12 Swissc-Darfon keyboard E-6

Figure E-13 IT new keyboard..... E-7

Tables

Table B-1	System board ICs (top and bottom)	B-3
Table B-2	System board connectors (top and bottom)	B-4
Table C-1	SODIMM I/F pin assignments (200-PIN)	C-1
Table C-2	LCD I/F pin assignments (22-pin)	C-5
Table C-3	RGB I/F pin assignments (15-pin).....	C-6
Table C-4	HDD I/F pin assignments (44-pin)	C-7
Table C-5	ODD I/F pin assignments (50-pin)	C-8
Table C-6	Parallel I/F pin assignments (25-pin).....	C-9
Table C-7	PC Card I/F pin assignments (84-pin)	C-10
Table C-8	Mini PCI I/F pin assignments (124-pin).....	C-12
Table C-9-1	JP18 Fan I/F pin assignments (3-pin)	C-14
Table C-9-2	JP21 Fan I/F pin assignments (3-pin)	C-14
Table C-10	AC Adaptor Connector pin assignments (3-pin)	C-14
Table C-11	Line in I/F pin assignments (6-pin).....	C-14
Table C-12	Microphone I/F pin assignments (6-pin).....	C-15
Table C-13	Microphone I/F pin assignments (6-pin).....	C-15
Table C-14	Headphone Connector pin assignments (6-pin).....	C-15
Table C-15	Headphone Connector pin assignments (6-pin).....	C-15
Table D-1	Scan codes (set 1 and set 2)	D-1
Table D-2	Scan codes with left Shift key.....	D-5
Table D-3	Scan codes in Numlock mode.....	D-6
Table D-4	Scan codes with Fn key.....	D-6
Table D-5	Scan codes in overlay mode.....	D-7
Table D-6	No.124 key scan code	D-7
Table D-7	No.126 key scan code	D-8
Table F-1	Series Screw Torque List	F-1
Table G-1	MTBF.....	G-1

Appendix A Handling the LCD Module

Precautions for handling the LCD module

The LCD module can be easily damaged during assembly or disassembly. Therefore, please observe the following precautions when handling it:

1. When installing the LCD module in the LCD cover, be sure to seat it so that it is properly aligned and maximum visibility of the display is maintained.

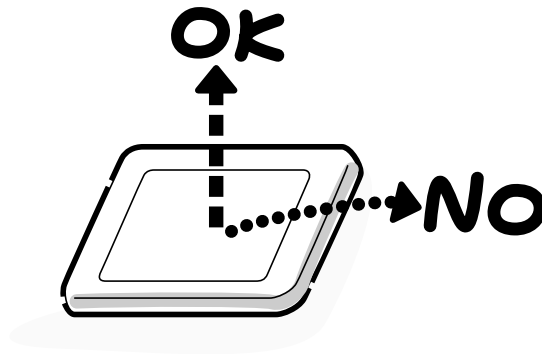

2. Be careful to align the holes at the four corners of the LCD module with the corresponding holes in the LCD cover before securing the module with screws. Do not force the module into place, because stress can affect its performance.

Note: The panel's polarized surface is easily scarred, so handle it carefully.



3. If the panel's surface gets dirty, wipe it with cotton or a soft cloth. If it is still dirty, try breathing on the surface to create a light condensate and wipe it again.

If the surface is very dirty, we recommend a CRT cleaning agent. Apply the agent to a cloth and then wipe the panel's surface. Do not apply cleanser directly to the panel.



4. If water or other liquid is left on the panel's surface for a long period, it can change the screen's tint or stain it. Be sure to quickly wipe off any liquid.



5. Glass is used in the panel, so be careful not to drop it or let it strike a hard object, which could cause breakage or cracks.

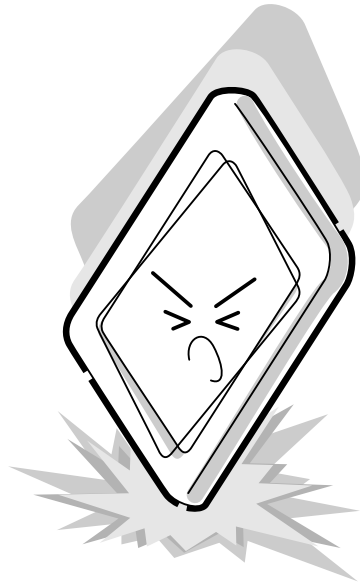

6. CMOS-LSI circuits are used in the module, so guard against damage from electrostatic discharge. Be sure to wear a wrist or ankle ground when handling the module.

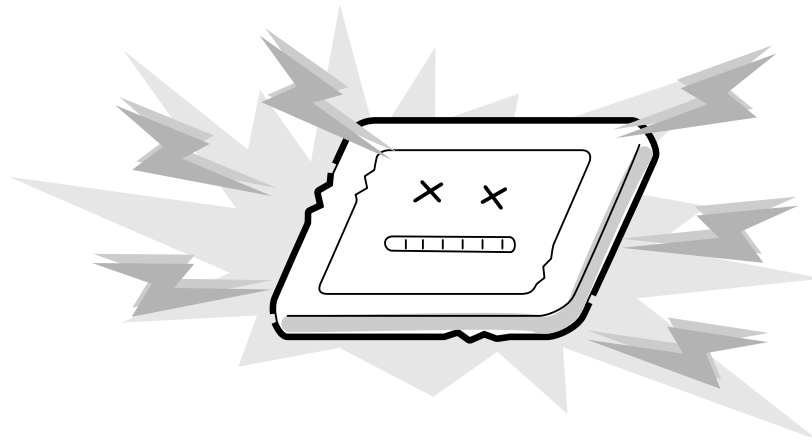

7. Do not expose the module to direct sunlight or strong ultraviolet rays for long periods.

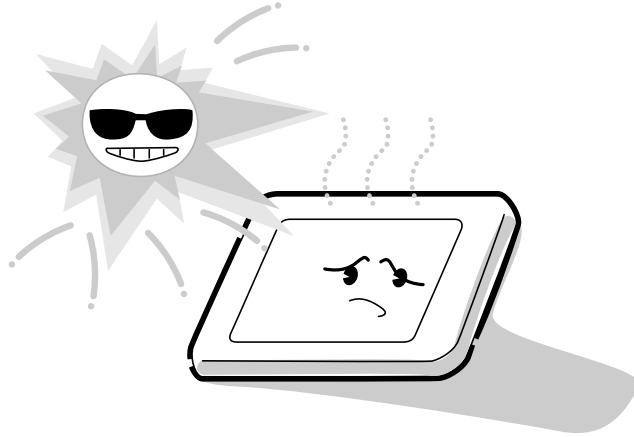

8. Do not store the module at temperatures below specifications. Cold can cause the liquid crystals to freeze, lose their elasticity or otherwise suffer damage.

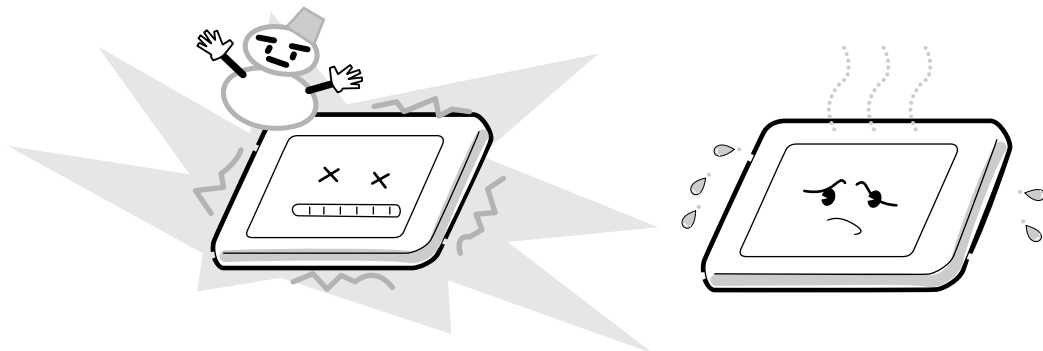

9. Do not disassemble the LCD module. Disassembly can cause malfunctions.

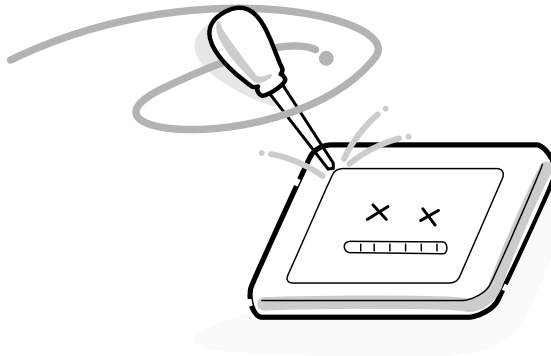

10. If you transport the module, do not use packing material that contains epoxy resin (amine) or silicon glue (alcohol or oxime). These materials can release gas that can damage the panel's polarization.

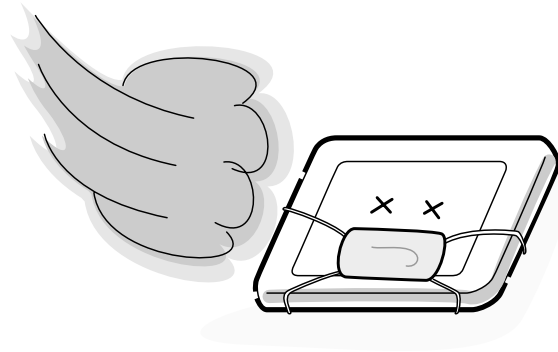

Appendix B Board Layout

B.1 System Board (FRDSY*) Top View

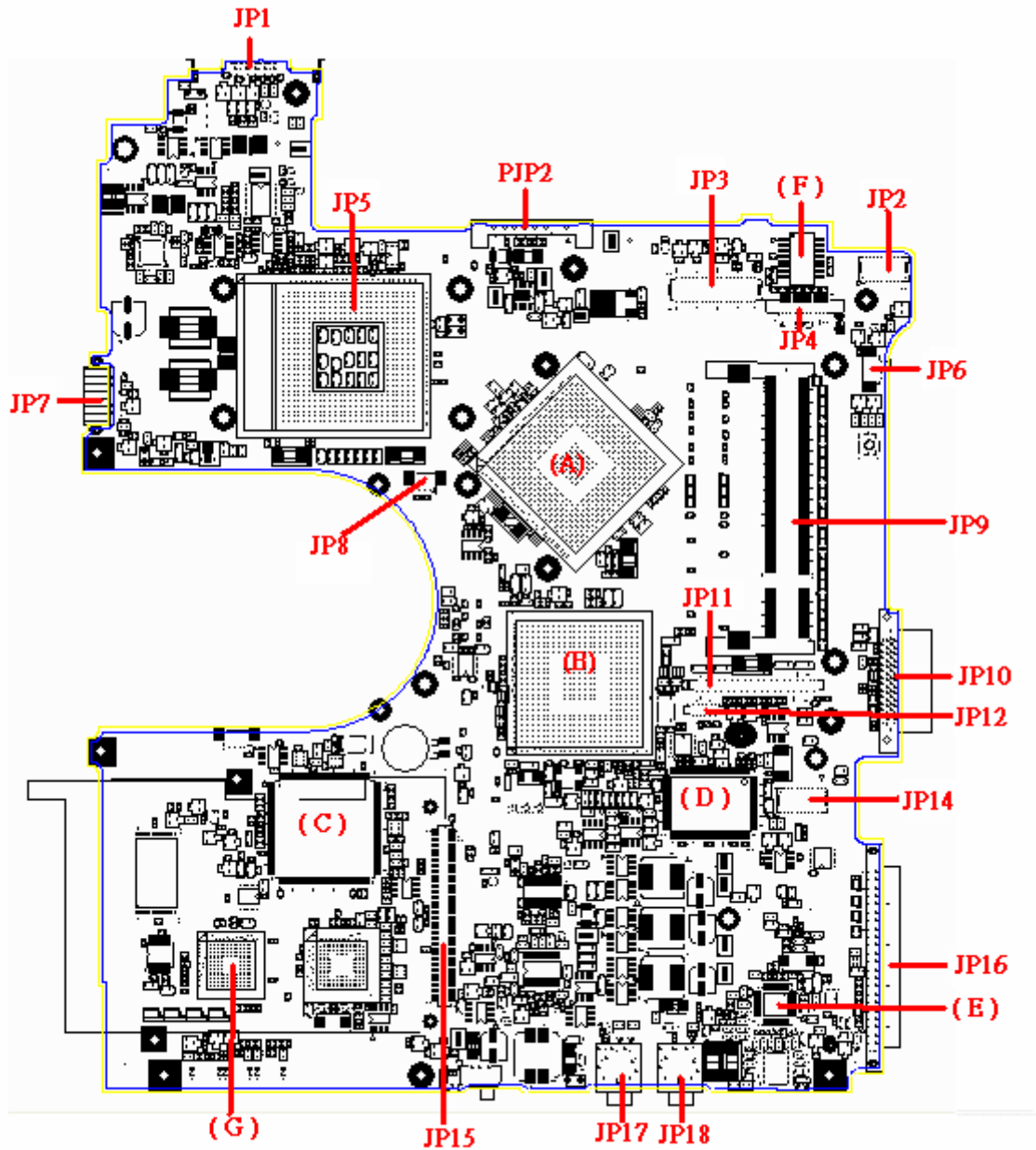

Figure B-1 System board (FRDSY*) layout (Top)

B.2 System Board (FRDSY*) Button View

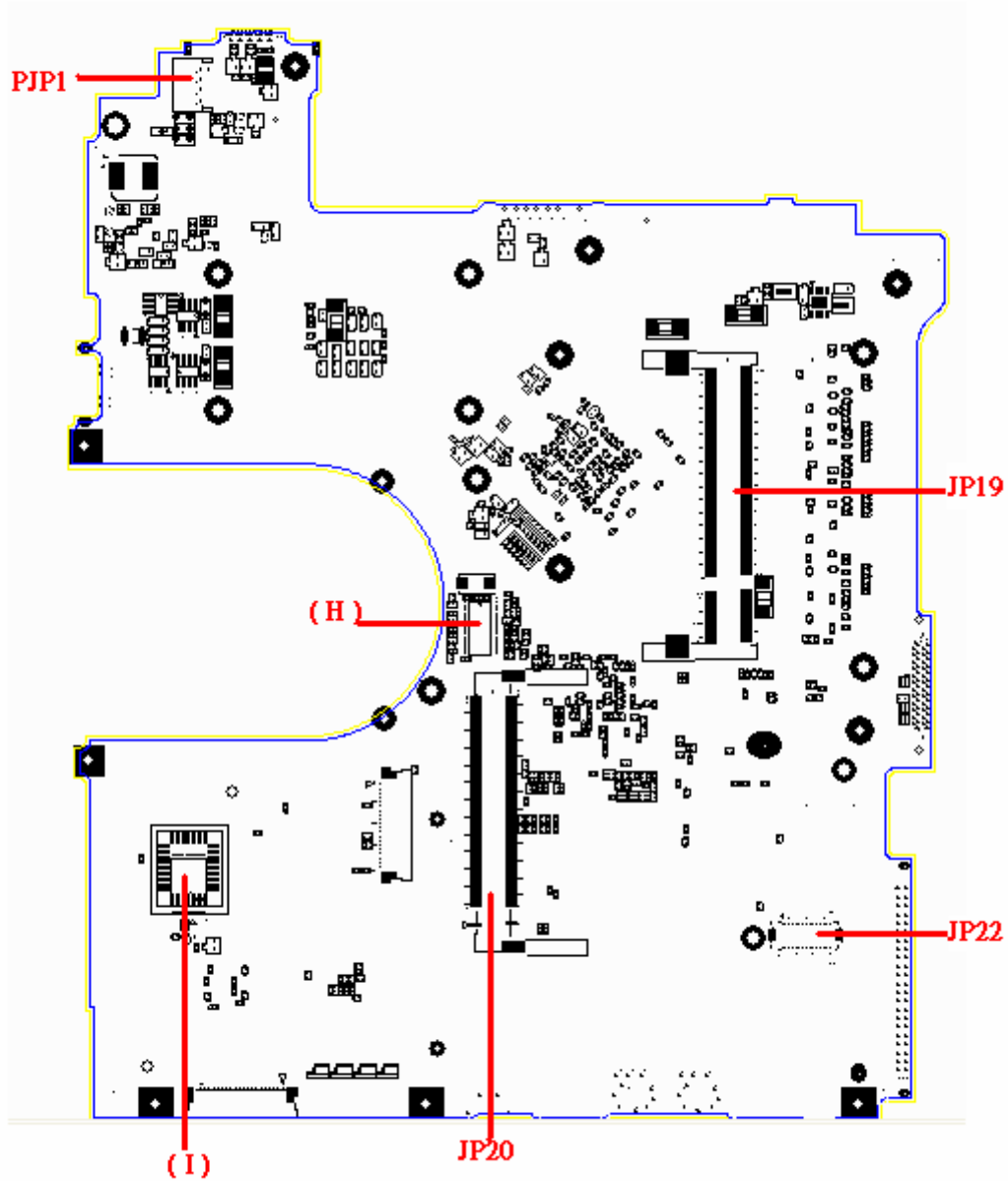

Figure B-2 System board (FRDSY*) layout (Button)

Table B-1 System board ICs (top and bottom)

Mark	Number	Name
(A)	U6	ATI –RL300MB
(B)	U9	SB200
(C)	U15	ENE 910
(D)	U13	REALTEK 8100CL
(E)	U28	RealTEK ALC250VD
(F)	U5	Transformer-NS0013
(G)	U25	TI PCI1410
(H)	U32	ICS951402AGT
(I)	U16	BIOS ROM

Table B-2 System board connectors (top and bottom)

Number	Name
JP1	CRT conn.
JP2	LAN/B conn.
JP4	Power/B conn.
JP3	LVDS conn
JP5	CPU Stocket
JP6	Spearker conn
JP7	TV-Out
JP8	Fan conn
JP11	KB conn
JP12	TP conn
JP14	USB/B conn
JP16	HDD conn
JP15	PCMCIA Conn
JP17, JP18	Audio jack
JP9, JP19	DDR conn
JP20	Mini-PCI conn
JP22	MDC conn
JP10	ODD conn
PJP1	Power core conn
PJP2	Battery conn

Appendix C Pin Assignments

System Board

C.1 JP9,JP19

Table C-1 SODIMM I/F pin assignments (200-PIN) (1/4)

Pin No.	Signal name	I/O	Pin No.	Signal Name	I/O
1	VREF	O	2	VREF	O
3	VSS	-	4	VSS	-
5	DQ0	I/O	6	DQ4	I/O
7	DQ1	I/O	8	DQ5	I/O
9	25VDD	O	10	2.5VDD	O
11	DQS0	I/O	12	DM0	O
13	DQ2	I/O	14	DQ6	I/O
15	VSS	-	16	VSS	-
17	DQ3	I/O	18	DQ7	I/O
19	DQ8	I/O	20	DQ12	I/O
21	2.5VDD	O	22	2.5VDD	O
23	DQ9	I/O	24	DQ13	I/O
25	DQS1	I/O	26	DM1	O
27	VSS	-	28	VSS	-
29	DQ10	I/O	30	DQ14	I/O
31	DQ11	I/O	32	DQ15	I/O
33	2.5VDD	O	34	2.5VDD	O
35	CK0	O	36	2.5VDD	O
37	CK0#	O	38	VSS	-
39	VSS	-	40	VSS	-
41	DQ16	I/O	42	DQ20	I/O
43	DQ17	I/O	44	DQ21	I/O
45	2.5VDD	O	46	2.5VDD	O
47	DQS2	I/O	48	DM2	O
49	DQ18	I/O	50v	DQ22	I/O

Table C-1 SODIMM I/F pin assignments (200-PIN) (2/4)

Pin No.	Signal name	I/O	Pin No.	Signal Name	I/O
51	VSS	-	52	VSS	-
53	DQ19	I/O	54	DQ23	I/O
55	DQ24	I/O	56	DQ28	I/O
57	2.5VDD	O	58	2.5VDD	O
59	DQ25	I/O	60	DQ29	I/O
61	DQS3	I/O	62	DM3	O
63	VSS	-	64	VSS	-
65	DQ26	I/O	66	DQ30	I/O
67	DQ27	I/O	68	DQ31	I/O
69	2.5VDD	O	70	2.5VDD	O
71	CB0	-	72	CB4	-
73	CB1	-	74	CB5	-
75	VSS	-	76	VSS	-
77	DQS8	-	78	DM8	-
79	CB2	-	80	CB6	-
81	2.5VDD	O	82	2.5VDD	O
83	CB3	-	84	CB7	-
85	DU	-	86	DU/RESET#	-
87	VSS	-	88	VSS	-
89	CK2	-	90	VSS	-
91	CK2#	-	92	2.5VDD	O
93	2.5VDD	O	94	2.5VDD	O
95	CKE1	-	96	CKE0	O
97	DU/A13	-	98	DU/BA2	-
99	A12	-	100	A11	O
101	A9	O	102	A8	O
103	VSS	-	104	VSS	-
105	A7	O	106	A6	O
107	A5	O	108	A4	O
109	A3	O	110	A2	O
111	A1	O	112	A0	O
113	2.5VDD	O	114	2.5VDD	O

Table C-1 SODIMM I/F pin assignments (200-PIN) (3/4)

Pin No.	Signal name	I/O	Pin No.	Signal Name	I/O
115	A10/AP	O	116	BA1	O
117	BA0	O	118	RAS#	O
119	WE#	O	120	CAS#	O
121	SO#	O	122	S1#	-
123	DU	-	124	DU	-
125	VSS	-	126	VSS	-
127	DQ32	I/O	128	DQ36	I/O
129	DQ33	I/O	130	DQ37	I/O
131	2.5VDD	O	132	2.5VDD	O
133	DQS4	I/O	134	DM4	O
135	DQ34	I/O	136	DQ38	I/O
137	VSS	-	138	VSS	-
139	DQ35	I/O	140	DQ39	I/O
141	DQ40	I/O	142	DQ44	I/O
143	2.5VDD	O	144	2.5VDD	O
145	DQ41	I/O	146	DQ45	I/O
147	DQS5	I/O	148	DM5	O
149	VSS	-	150	VSS	-
151	DQ42	I/O	152	DQ46	I/O
153	DQ43	I/O	154	DQ47	I/O
155	2.5VDD	O	156	2.5VDD	O
157	2.5VDD	O	158	CK1#	O
159	VSS	-	160	CK1	O
161	VSS	-	162	VSS	-
163	DQ48	I/O	164	DQ52	I/O
165	DQ49	I/O	166	DQ53	I/O
167	2.5VDD	O	168	2.5VDD	O
169	DQS6	I/O	170	DM6	O
171	DQ50	I/O	172	DQ54	I/O
173	VSS	-	174	VSS	-
175	DQ51	I/O	176	DQ55	I/O
177	DQ56	I/O	178	DQ60	I/O
179	2.5VDD	O	180	2.5VDD	O

Table C-1 SODIMM I/F pin assignments (200-PIN) (4/4)

Pin No.	Signal name	I/O	Pin No.	Signal Name	I/O
181	DQ57	I/O	182	DQ61	I/O
183	DQS7	I/O	184	DM7	O
185	VSS	-	186	VSS	-
187	DQ58	I/O	188	DQ62	I/O
189	DQ59	I/O	190	DQ63	I/O
191	2.5VDD	O	192	2.5VDD	O
193	SDA	I/O	194	SA0	O
195	SCL	O	196	SA1	O
197	3.3VDD_SPD	O	198	SA2	O
199	VDD_ID	O	200	DU	-

C.2 JP1

Table C-2 RGB I/F pin assignments (15-pin)

Pin No.	Signal name	I/O	Pin No.	Signal Name	I/O
1	CRT_R	O	2	CRT_G	O
3	CRT_B	O	4	NC	-
5	GND	-	6	GND	-
7	GND	-	8	GND	-
9	+CRT_VCC	-	10	GND	-
11	NC	-	12	DDC_DATA	I/O
13	DACA_HSYNC	O	14	DACA_VSYNC	O
15	DDC_CLK	I/O			

C.3 JP15

Table C-3 HDD I/F pin assignments (44-pin)

Pin No.	Signal name	I/O	Pin No.	Signal Name	I/O
2	PIDE-RST#	O	1	GND	-
4	PDD7	I/O	3	PDD8	I/O
6	PDD6	I/O	5	PDD9	I/O
8	PDD5	I/O	7	PDD10	I/O
10	PDD4	I/O	9	PDD11	I/O
12	PDD3	I/O	11	PDD12	I/O
14	PDD2	I/O	13	PDD13	I/O
16	PDD1	I/O	15	PDD14	I/O
18	PDD0	I/O	17	PDD15	I/O
20	GND	-	19	NC	-
22	PDDREQ	I	21	NC	-
24	PDIOW#	O	23	GND	-
26	PDIOR#	O	25	GND	-
28	PDIORDY	I	27	PCSEL	O
30	PDDACK#	O	29	GND	-
32	IRQ14	I	31	NC	-
34	PDA1	O	33	NC	-
36	PDA0	O	35	PDA2	O
38	PDCS1#	O	37	PDCS3#	O
40	PHDD_LED#	I	39	GND	-
42	+5VS	-	41	+5VS	-
44	GND	-	43	NC	-

C.4 JP10

Table C-4 ODD I/F pin assignments (50-pin)

Pin No.	Signal name	I/O	Pin No.	Signal Name	I/O
1	INT_CD_L	I	2	INT_CD_R	I
3	CD_AGND	-	4	GND	-
5	SIDE_RST#	O	6	SDD8	I/O
7	SDD7	I/O	8	SDD9	I/O
9	SDD6	I/O	10	SDD10	I/O
11	SDD5	I/O	12	SDD11	I/O
13	SDD4	I/O	14	SDD12	I/O
15	SDD3	I/O	16	SDD13	I/O
17	SDD2	I/O	18	SDD14	I/O
19	SDD1	I/O	20	SDD15	I/O
21	SDD0	I/O	22	SDDREQ	I
23	GND	-	24	SDIOR#	O
25	SDIOW#	O	26	GND	O
27	SIORDY	I	28	SDDACK#	O
29	IRQ15	I	30	NC	O
31	SDA1	O	32	+5VCD	I
33	SDA0	O	34	SDA2	I
35	SDCS1#	O	36	SDCS3#	-
37	SHDD_LED#	I	38	+5VCD	O
39	+5VCD	-	40	+5VCD	-
41	+5VCD	-	42	+5VCD	-
43	GND	-	44	GND	-
45	GND	-	46	GND	-
47	GND	-	48	GND	-
49	NC	-	50	NC	-

C.5 JP15

Table C-5 PC Card I/F pin assignments (88-pin) (1/2)

Pin No.	Signal name	I/O	Pin No.	Signal Name	I/O
1	GND	-	35	GND	-
2	S1_D3	I/O	36	S1_CD1#	O
3	S1_D4	I/O	37	S1_D11	I/O
4	S1_D5	I/O	38	S1_D12	I/O
5	S1_D6	I/O	39	S1_D13	I/O
6	S1_D7	I/O	40	S1_D14	I/O
7	S1_CE1#	I/O	41	S1_D15	I/O
8	S1_A10	I	42	S1_CE2#	I/O
9	S1_OE#	I/O	43	S1_VS1	I
10	S1_A11	I	44	S1_IORD#	I/O
11	S1_A9	I	45	S1_IOWR#	I
12	S1_A8	I	46	S1_A17	I
13	S1_A13	I	47	S1_A18	I
14	S1_A14	I	48	S1_A19	I
15	S1_WE#	I	49	S1_A20	I
16	S1_RDY#	O	50	S1_A21	I
17	+S1_VCC	-	51	+S1_VCC	-
18	+S1_VPP	-	52	+S1_VPP	-
19	S1_A16	I	53	S1_A22	I
20	S1_A15	I	54	S1_A23	I
21	S1_A12	I	55	S1_A24	I
22	S1_A7	I	56	S1_A25	I
23	S1_A6	I	57	S1_VS2	I
24	S1_A5	I	58	S1_RST	I
25	S1_A4	I	59	S1_WAIT#	I
26	S1_A3	I	60	S1_INPACK#	O
27	S1_A2	I	61	S1_REG#	I
28	S1_A1	I	62	S1_BVD2	O
29	S1_A0	I	63	S1_BVD1	I
30	S1_D0	I	64	S1_D8	I/O

Table C-5 PC Card I/F pin assignments (88-pin) (2/2)

Pin No.	Signal name	I/O	Pin No.	Signal Name	I/O
31	S1_D1	I/O	65	S1_D9	I/O
32	S1_D2	I/O	66	S1_D10	I/O
33	S1_WP	I/O	67	S1_CD2#	I
34	GND	-	68	GND	-
69	GND	-	70	GND	-
71	GND	-	72	GND	-
73	GND	-	74	GND	-
75	GND	-	76	GND	-
77	GND	-	78	GND	-
79	GND	-	80	GND	-
81	GND	-	82	GND	-
83	GND	-	84	GND	-
85	GND	-	86	GND	-
87	GND	-	88	GND	-

C.6 JP20

Table C-6 Mini PCI I/F pin assignments (124-pin) (1/2)

Pin No.	Signal name	I/O	Pin No.	Signal Name	I/O
1	NC	-	2	NC	-
3	NC	-	4	NC	-
5	NC	-	6	NC	-
7	NC	-	8	NC	-
9	NC	-	10	NC	-
11	NC	-	12	NC	-
13	SWITCH	O	14	NC	-
15	NC	-	16	NC	-
17	PIRQH#	I	18	+5VS_MINIPCI	-
19	+3.3V	O	20	PIRQG#	I
21	NC	-	22	NC	-
23	GND	-	24	+3.3V	O
25	PCICLK	O	26	PCIRST#	O
27	GND	-	28	+3.3V	O
29	REQ1#	I	30	GNT1#	O
31	+3.3V	O	32	GND	-
33	AD31	I/O	34	WLANME#	I
35	AD29	I/O	36	NC	-
37	GND	-	38	AD30	I/O
39	AD27	I/O	40	+3.3V	O
41	AD25	I/O	42	AD28	I/O
43	NC	-	44	AD26	I/O
45	CBE3#	I/O	46	AD24	I/O
47	AD23	I/O	48	MINI_IDSEL	I/O
49	GND	-	50	GND	-
51	AD21	I/O	52	AD22	I/O
53	AD19	I/O	54	AD20	I/O
55	GND	-	56	PAR	I/O
57	AD17	I/O	58	AD18	I/O
59	CBE2#	I/O	60	AD16	I/O

Table C-6 Mini PCI I/F pin assignments (124-pin)(2/2)

Pin No.	Signal name	I/O	Pin No.	Signal Name	I/O
61	IRDY#	I/O	62	GND	-
63	+3.3V	O	64	FRAME#	I/O
65	PM_CLKRUN#	I/O	66	TRDY#	I/O
67	PCI_SERR#	I/O	68	STOP#	I/O
69	GND	-	70	+3.3V	O
71	PCI_PERR#	O	72	DEVSEL#	I/O
73	C/BE1#	I/O	74	GND	-
75	AD14	I/O	76	AD15	I/O
77	GND	-	78	AD13	I/O
79	AD12	I/O	80	AD11	I/O
81	AD10	I/O	82	GND	-
83	GND	-	84	AD09	I/O
85	AD08	I/O	86	C/BE0#	I/O
87	AD07	I/O	88	+3.3V	O
89	+3.3V	O	90	AD06	I/O
91	AD05	I/O	92	AD04	I/O
93	NC	-	94	AD02	I/O
95	AD03	I/O	96	AD00	I/O
97	+5VS_MINIPCI	O	98	NC	-
99	AD01	I/O	100	NC	-
101	GND	-	102	GND	-
103	NC	-	104	NC	-
105	NC	-	106	NC	-
107	NC	-	108	NC	-
109	NC	-	110	NC	-
111	NC	I	112	NC	-
113	GND	-	114	GND	-
115	NC	-	116	NC	-
117	GND	-	118	GND	-
119	GND	-	120	GND	-
121	NC	-	122	NC	-
123	+5VS_MINIPCI	-	124	+3.3V	-

C.7 JP6

Pin No.	Signal name	Function
1	B+	Power
2	DAC_BRIG	Inverter Control signal
3	B+	Power
4	INVT_PWM	Inverter Control signal
5	NC	Non-Connection
6	DISPOFF#	Inverter Control signal
7	+3VS	DDC 3.3V POWER SUPPLY : +3.3V
8	+LCDVDD	Power for Panel
9	NB_EDID_CLK	DDC Clock
10	+LCDVDD	Power for Panel
11	NB_EDID_DAT	DDC DATA
12	+LCDVDD	Power for Panel
13	Vss	GND
14	Vss	GND
15	TXB0-_NB	Panel Data Signals
16	TXA0-_NB	Panel Data Signals
17	TXB0+_NB	Panel Data Signals
18	TXA0+_NB	Panel Data Signals
19	Vss	GND
20	Vss	GND
21	TXB1+_NB	Panel Data Signals
22	TXA1-_NB	Panel Data Signals
23	TXB1-_NB	Panel Data Signals
24	TXA1+_NB	Panel Data Signals
25	TXB2+_NB	Panel Data Signals
26	TXA2+_NB	Panel Data Signals
27	TXB2-_NB	Panel Data Signals
28	TXA2-_NB	Panel Data Signals
29	Vss	GND
30	Vss	GND
31	TXBCLK-_NB	Panel Clock Signals
32	TXACLK-_NB-	Panel Clock Signals
33	TXBCLK+_NB	Panel Clock Signals

34	TXACLK+_NB	Panel Clock Signals
35	NC	Non-Connection
36	NC	Non-Connection
37	NC	Non-Connection
38	NC	Non-Connection
39	NC	No EDID Panel Detect
40	VSS	GND

C.8 JP8

Table C-8 JP8 Fan I/F pin assignments (3-pin)

Pin No.	Signal name	I/O	Pin No.	Signal Name	I/O
1	FAN1	I	2	FAN-SPEED1	O
3	GND	-			

C.9 PJP1

Table C-9 AC Adaptor Connector pin assignments (3-pin)

Pin No.	Signal name	I/O	Pin No.	Signal Name	I/O
1	DC_IN_S2	I	2	DC_IN_S2	-
3	GND	-	4	GND	-

C.10 JP18

Table C-10 Microphone I/F pin assignments (6-pin)

Pin No.	Signal name	I/O	Pin No.	Signal Name	I/O
1	ANGND	-	2	MIC	I
3	BIAS	I	4	NC	-
5	NC	-	6	ANGND	-

C.11 JP17

Table C-11 Headphone Connector pin assignments (6-pin)

Pin No.	Signal name	I/O	Pin No.	Signal Name	I/O
1	ANGND	-	2	INTSPK_L1	O
3	INTSPK_R1	O	4	NBA_PLUG	I
5	ANGND	-	6	NC	-

Appendix D Keyboard Scan/Character Codes

Table D-1 Scan codes (set 1 and set 2) (1/4)

Cap No.	Keytop	Code set 1		Code set 2		Note	
		Make	Break	Make	Break		
01	' ~	29	A9	0E	F0	0E	
02	1 !	02	82	16	F0	16	
03	2 @	03	83	1E	F0	1E	
04	3 #	04	84	26	F0	26	
05	4 \$	05	85	25	F0	25	
06	5 %	06	86	2E	F0	2E	
07	6 ^	07	87	36	F0	36	
08	7 &	08	88	3D	F0	3D	*2
09	8 *	09	89	3E	F0	3E	*2
10	9 (0A	8A	46	F0	46	*2
11	0)	0B	8B	45	F0	45	
12	- _	0C	8C	4E	F0	4E	
13	= +	0D	8D	55	F0	55	
15	BkSp	0E	8E	66	F0	66	
16	Tab	0F	8F	0D	F0	0D	
17	Q	10	90	15	F0	15	
18	W	11	91	1D	F0	1D	
19	E	12	92	24	F0	24	
20	R	13	93	2D	F0	2D	
21	T	14	94	2C	F0	2C	
22	Y	15	95	35	F0	35	
23	U	16	96	3C	F0	3C	*2
24	I	17	97	43	F0	43	*2
25	O	18	98	44	F0	44	*2
26	P	19	99	4D	F0	4D	*2
27	[{	1A	9A	54	F0	54	
28] }	1B	9B	5B	F0	5B	

Table D-1 Scan codes (set 1 and set 2) (2/4)

Cap No.	Keypop	Code set 1		Code set 2			Note
		Make	Break	Make	Break		
29	\	2B	AB	5D	F0	5D	*5
30	Caps Lock	3A	BA	58	F0	58	
31	A	1E	9E	1C	F0	1C	
32	S	1F	9F	1B	F0	1B	
33	D	20	A0	23	F0	23	
34	F	21	A1	2B	F0	2B	
35	G	22	A2	34	F0	34	
36	H	23	A3	33	F0	33	
37	J	24	A4	3B	F0	3B	*2
38	K	25	A5	42	F0	42	*2
39	L	26	A6	4B	F0	4B	*2
40	; :	27	A7	4C	F0	4C	*2
41	' "	28	A8	52	F0	52	
43	Enter	1C	9C	5A	F0	5A	*3
44	Shift (L)	2A	AA	12	F0	12	
45	No.102 key	56	D6	61	F0	61	
46	Z	2C	AC	1A	F0	1A	
47	X	2D	AD	22	F0	22	
48	C	2E	AE	21	F0	21	
49	V	2F	AF	2A	F0	2A	
50	B	30	B0	32	F0	32	
51	N	31	B1	31	F0	31	
52	M	32	B2	3A	F0	3A	*2
53	, <	33	B3	41	F0	41	*2
54	. >	34	B4	49	F0	49	*2
55	/ ?	35	B5	4A	F0	4A	*2
57	Shift (R)	36	B6	59	F0	59	

Table D-1 Scan codes (set 1 and set 2) (3/4)

Cap No.	Keypop	Code set 1		Code set 2			Note
		Make	Break	Make	Break		
58	Ctrl(L)	1D	9D	14	F0	14	*3
60	Alt (L)	38	B8	11	F0	11	*3
61	Space	39	B9	29	F0	29	
62	ALT (R)	E0 38	E0 B8	E0 11	E0 F0	11	
64	Ctrl(R)	E0 1D	E0 9D	E0 14	E0 F0	14	
75	Ins	E0 52	E0 D2	E0 70	E0 F0	70	*1
76	Del	E0 53	E0 D3	E0 71	E0 F0	71	*1
79	←	E0 4B	E0 CB	E0 6B	E0 F0	6B	*1
80	Home	E0 47	E0 C7	E0 6C	E0 F0	6C	*1
81	End	E0 4F	E0 CF	E0 69	E0 F0	69	*1
83	↑	E0 48	E0 C8	E0 75	E0 F0	75	*1
84	↓	E0 50	E0 D0	E0 72	E0 F0	72	*1
85	PgUp	E0 49	E0 C9	E0 7D	E0 F0	7D	*1
86	PgDn	E0 51	E0 D1	E0 7A	E0 F0	7A	*1
89	→	E0 4D	E0 CD	E0 74	E0 F0	74	*1
110	Esc	01	81	76	F0	76	
112	F1	3B	BB	05	F0	05	
113	F2	3C	BC	06	F0	06	
114	F3	3D	BD	04	F0	04	
115	F4	3E	BE	0C	F0	0C	
116	F5	3F	BF	03	F0	03	
117	F6	40	C0	0B	F0	0B	
118	F7	41	C1	83	F0	83	
119	F8	42	C2	0A	F0	0A	
120	F9	43	C3	01	F0	01	
121	F10	44	C4	09	F0	09	*3

Table D-1 Scan codes (set 1 and set 2) (4/4)

Cap No.	Keytop	Code set 1				Code set 2				Note
		Make		Break		Make		Break		
122	F11	57		D7		78		F0 78		*3
123	F12	58		D8		07		F0 07		*3
124	PrintSc	*6		*6		*6		*6		*6
126	Pause	*7		*7		*7		*7		*7
X	Fn	—		—		—		—		*4
X	Win	E0	5B	E0	DB	E0	1F	E0	F0 1F	
x	App	E0	5D	E0	DD	E0	2F	E0	F0 2F	

Notes:

1. * Scan codes differ by mode.
2. * Scan codes differ by overlay function.
3. * Combination with the **Fn** key gives different codes.
4. * The **Fn** key does not generate a code by itself.
5. * This key corresponds to key No. 42 in a 102-key model.
6. * Refer to Table D-6, No. 124 key scan code.
7. * Refer to Table D-7, No. 126 key scan code.

Table D-2 Scan codes with left Shift key

Cap No.	Key top	Code set 1		Code set 2	
		Make	Break	Make	Break
55	/	E0 AA E0 35	E0 B5 E0 2A	E0 F0 12 E0 4A	E0 F0 4A E0 12
75	INS	E0 AA E0 52	E0 D2 E0 2A	E0 F0 12 E0 70	E0 F0 70 E0 12
76	DEL	E0 AA E0 53	E0 D3 E0 2A	E0 F0 12 E0 71	E0 F0 71 E0 12
79	←	E0 AA E0 4B	E0 CB E0 2A	E0 F0 12 E0 6B	E0 F0 6B E0 12
80	Home	E0 AA E0 47	E0 C7 E0 2A	E0 F0 12 E0 6C	E0 F0 6C E0 12
81	End	E0 AA E0 4F	E0 CF E0 2A	E0 F0 12 E0 69	E0 F0 69 E0 12
83	↑	E0 AA E0 48	E0 C8 E0 2A	E0 F0 12 E0 75	E0 F0 75 E0 12
84	↓	E0 AA E0 50	E0 D0 E0 2A	E0 F0 12 E0 72	E0 F0 72 E0 12
85	PgUp	E0 AA E0 49	E0 C9 E0 2A	E0 F0 12 E0 7D	E0 F0 7D E0 12
86	PgDn	E0 AA E0 51	E0 D1 E0 2A	E0 F0 12 E0 7A	E0 F0 7A E0 12
89	→	E0 AA E0 4D	E0 CD E0 2A	E0 F0 12 E0 74	E0 F0 74 E0 12
X	Win	E0 AA E0 5B	E0 DB E0 2A	E0 F0 12 E0 1F	E0 F0 1F E0 12
X	App	E0 AA E0 5D	E0 DD E0 2A	E0 F0 12 E0 2F	E0 F0 2F E0 12

Note : The table above shows scan codes with the left **Shift** key. In combination with the right **Shift** key, scan codes are changed as listed below:

	With left Shift	With right Shift
Set 1	E0 AA _____	E0 B6
	E0 2A _____	E0 36
Set 2	E0 F0 12 _____	E0 F0 59
	E0 12 _____	E0 59

Table D-3 Scan codes in Numlock mode

Cap No.	Key top	Code set 1				Code set 2			
		Make		Break		Make		Break	
75	INS	E0 2A	E0 52	E0 D2	E0 AA	E0 12	E0 70	E0 F0	70 E0 F0 12
76	DEL	E0 2A	E0 53	E0 D3	E0 AA	E0 12	E0 71	E0 F0	71 E0 F0 12
79	←	E0 2A	E0 4B	E0 CB	E0 AA	E0 12	E0 6B	E0 F0	6B E0 F0 12
80	Home	E0 2A	E0 47	E0 C7	E0 AA	E0 12	E0 6C	E0 F0	6C E0 F0 12
81	End	E0 2A	E0 4F	E0 CF	E0 AA	E0 12	E0 69	E0 F0	69 E0 F0 12
83	↑	E0 2A	E0 48	E0 C8	E0 AA	E0 12	E0 75	E0 F0	75 E0 F0 12
84	↓	E0 2A	E0 50	E0 D0	E0 AA	E0 12	E0 72	E0 F0	72 E0 F0 12
85	PgUp	E0 2A	E0 49	E0 C9	E0 AA	E0 12	E0 7D	E0 F0	7D E0 F0 12
86	PgDn	E0 2A	E0 51	E0 D1	E0 AA	E0 12	E0 7A	E0 F0	7A E0 F0 12
89	→	E0 2A	E0 4D	E0 CD	E0 AA	E0 12	E0 74	E0 F0	74 E0 F0 12
X	Win	E0 2A	E0 5B	E0 DB	E0 AA	E0 12	E0 1F	E0 F0	1F E0 F0 12
X	App	E0 2A	E0 5D	E0 DD	E0 AA	E0 12	E0 2F	E0 F0	2F E0 F0 12

Table D-4 Scan codes with Fn key

Cap No.	Keytop	Code set 1		Code set 2	
		Make	Break	Make	Break
43	ENT	E0 1C	E0 9C	E0 5A	E0 F0 5A
58	L-CTRL	E0 1D	E0 9D	E0 14	E0 F0 14
60	L-ALT	E0 38	E0 B8	E0 11	E0 F0 11
121	ARROW	45	C5	77	F0 77
122	NUMERIC	45	C5	77	F0 77
123	ScrL	46	C6	7E	F0 7E

Table D-5 Scan codes in overlay mode

Cap No.	Keytop		Code set 1		Code set 2		
			Make	Break	Make	Break	
09	8	(8)	48	C8	75	F0	75
10	9	(9)	49	C9	7D	F0	7D
11	0	(*)	37	B7	7C	F0	7C
23	U	(4)	4B	CB	6B	F0	6B
24	I	(5)	4C	CC	73	F0	73
25	O	(6)	4D	CD	74	F0	74
26	P	(-)	4A	CA	7B	F0	7B
37	J	(1)	4F	CF	69	F0	69
38	K	(2)	50	D0	72	F0	72
39	L	(3)	51	D1	7A	F0	7A
40	;	(+)	4E	CE	79	F0	79
52	M	(0)	52	D2	70	F0	70
54	.	(.)	53	D3	71	F0	71
55	/	(/)	E0 35	E0 B5	E0 4A	E0 F0	4A

Table D-6 No.124 key scan code

Key top	Shift	Code set 1				Code set 2			
		Make		Break		Make		Break	
Prt Sc	Common	E0 2A	E0 37	E0 B7	E0 AA	E0 12	E0 7C	E0 F0 7C	E0 F0 12
	Ctrl +	E0 37		E0 B7		E0 7C		E0 F0 7C	
	Shift +	E0 37		E0 B7		E0 7C		E0 F0 7C	
	Alt +		54	D4		84		F0 84	

Table D-7 No.126 key scan code

Key top	Shift	Code set 1						Code set 2							
		Make						Make							
Pause	Common	E1	1D	45	E1	9D	C5	E1	14	77	E1	F0	14	F0	77
	Ctrl	E0	46	E0	C6			E0	7E	E0	F0	7E			

*: This key generates only make codes.

Appendix E Key Layout

E.1 United States (US) Keyboard

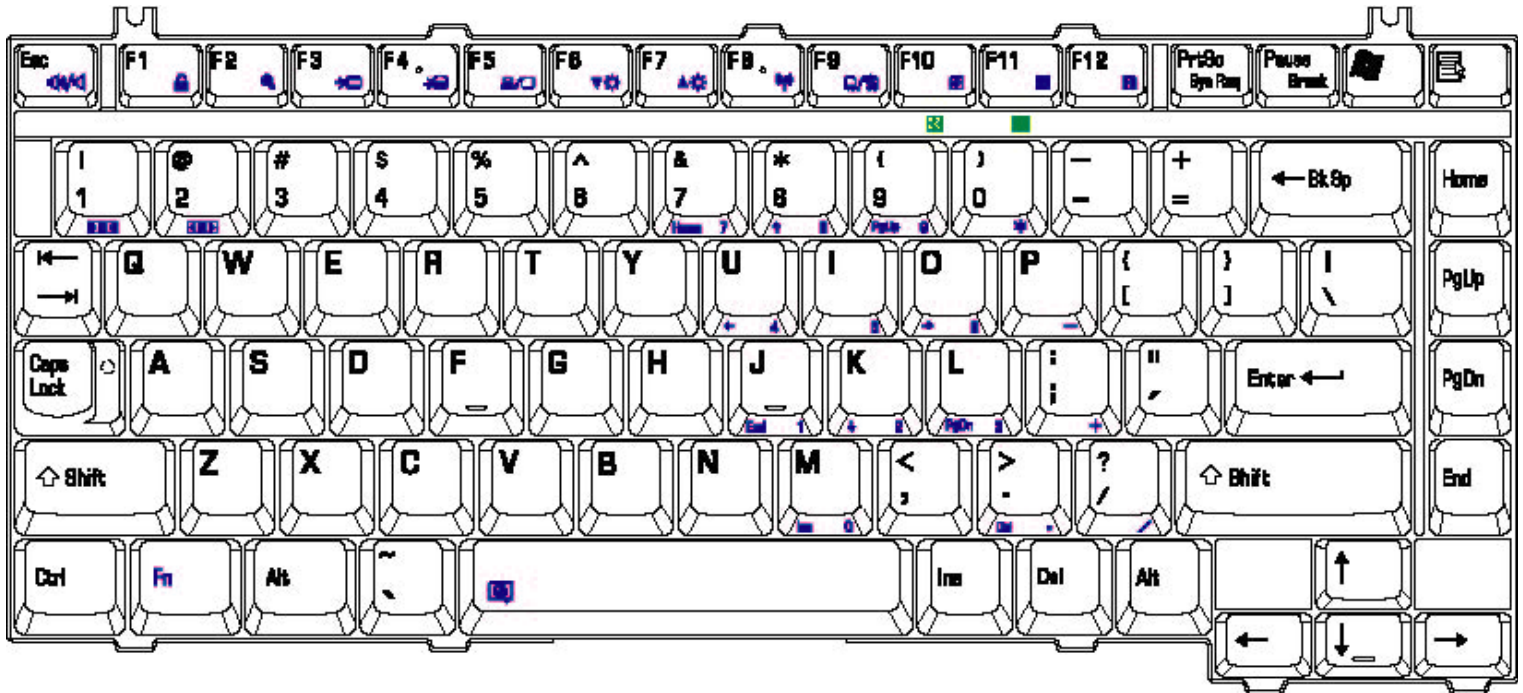

Figure E-1 US keyboard

E.2 United Kingdom (UK) Keyboard

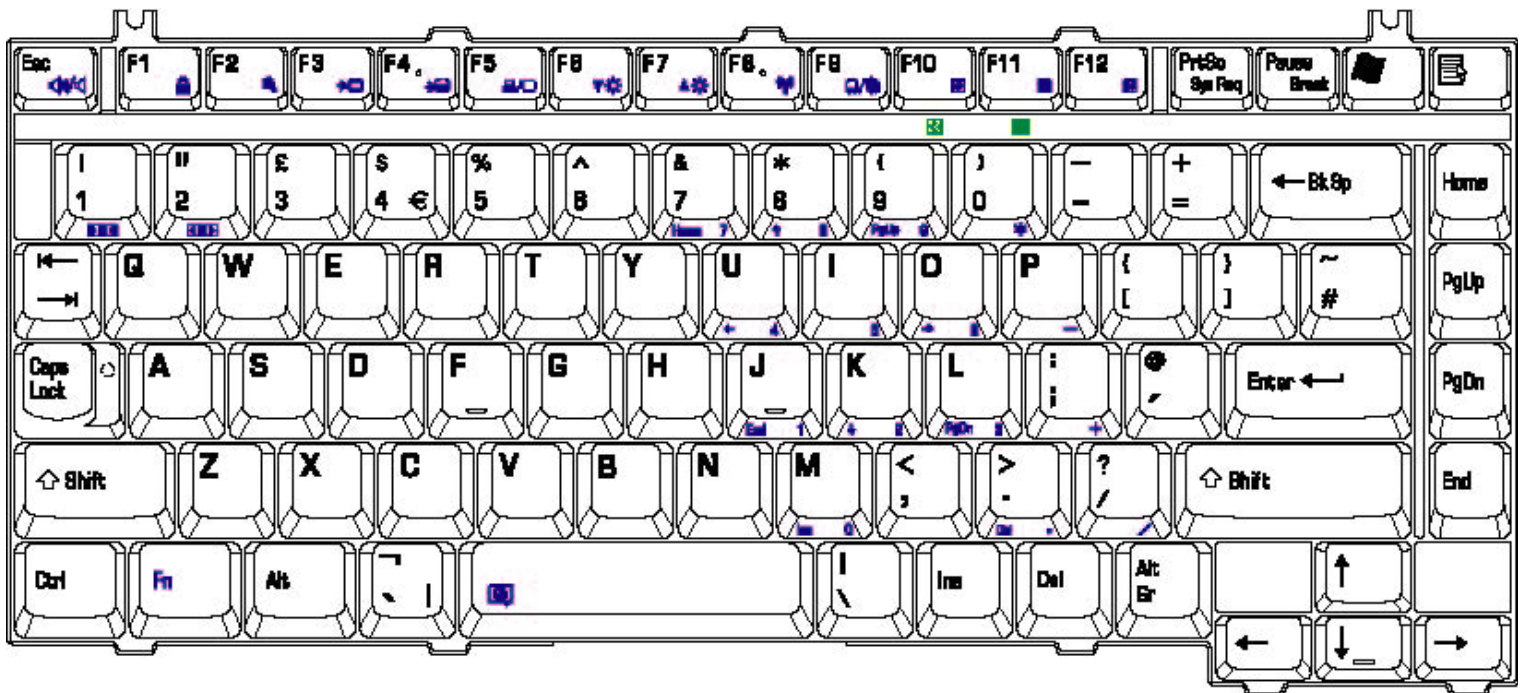

Figure E-2 UK keyboard

E.3 Spanish (SP) Keyboard

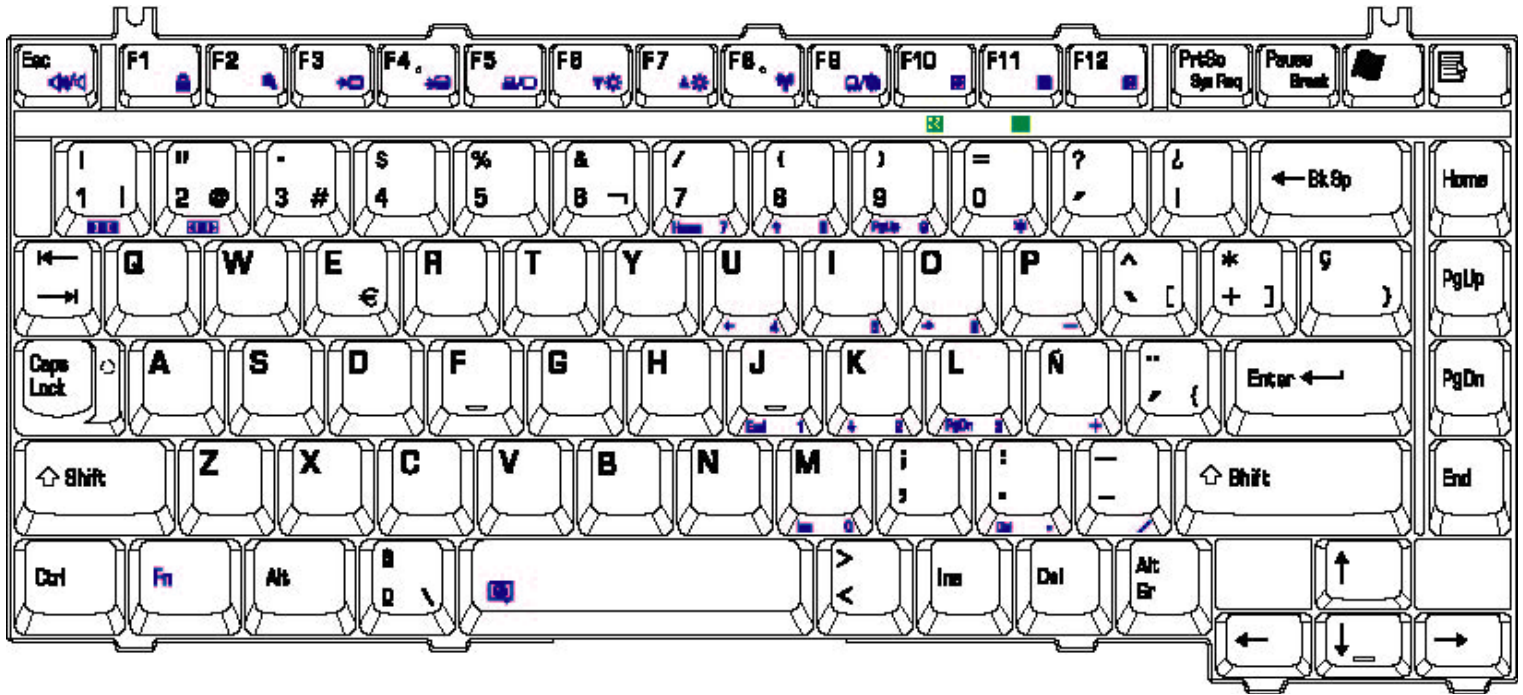

Figure E-3 SP keyboard

E.4 Japanese (JA) Keyboard

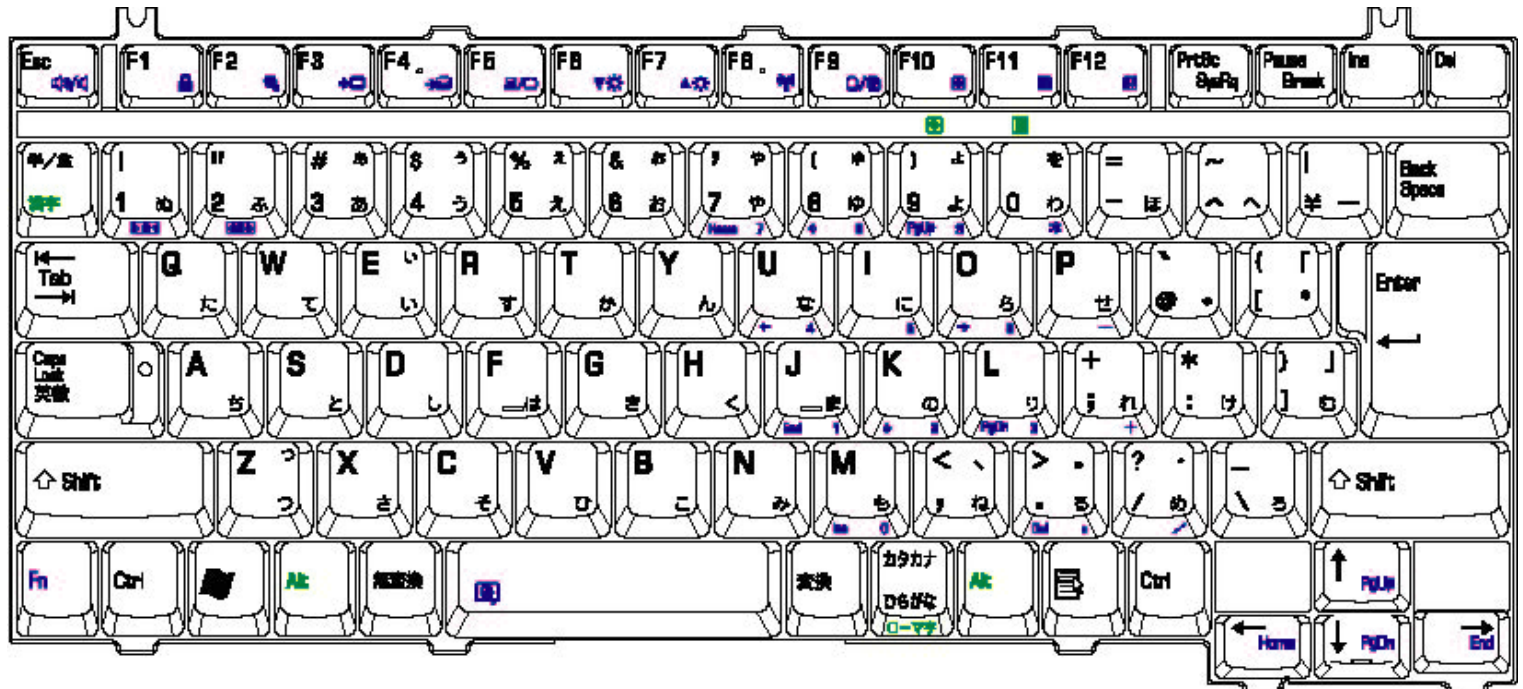

Figure E-4 JA keyboard

E.5 Korean (KO) Keyboard

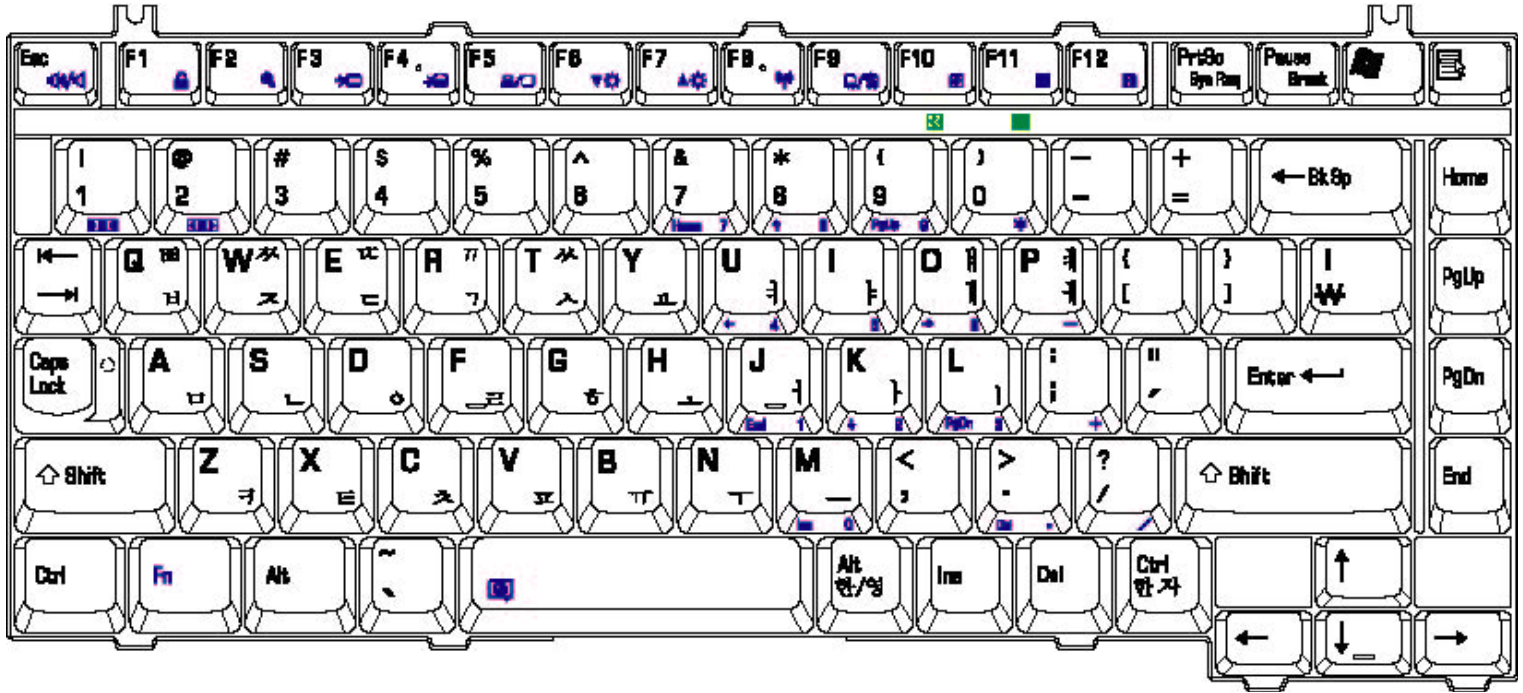

Figure E-5 KO keyboard

E.6 Canada France (CF) Keyboard

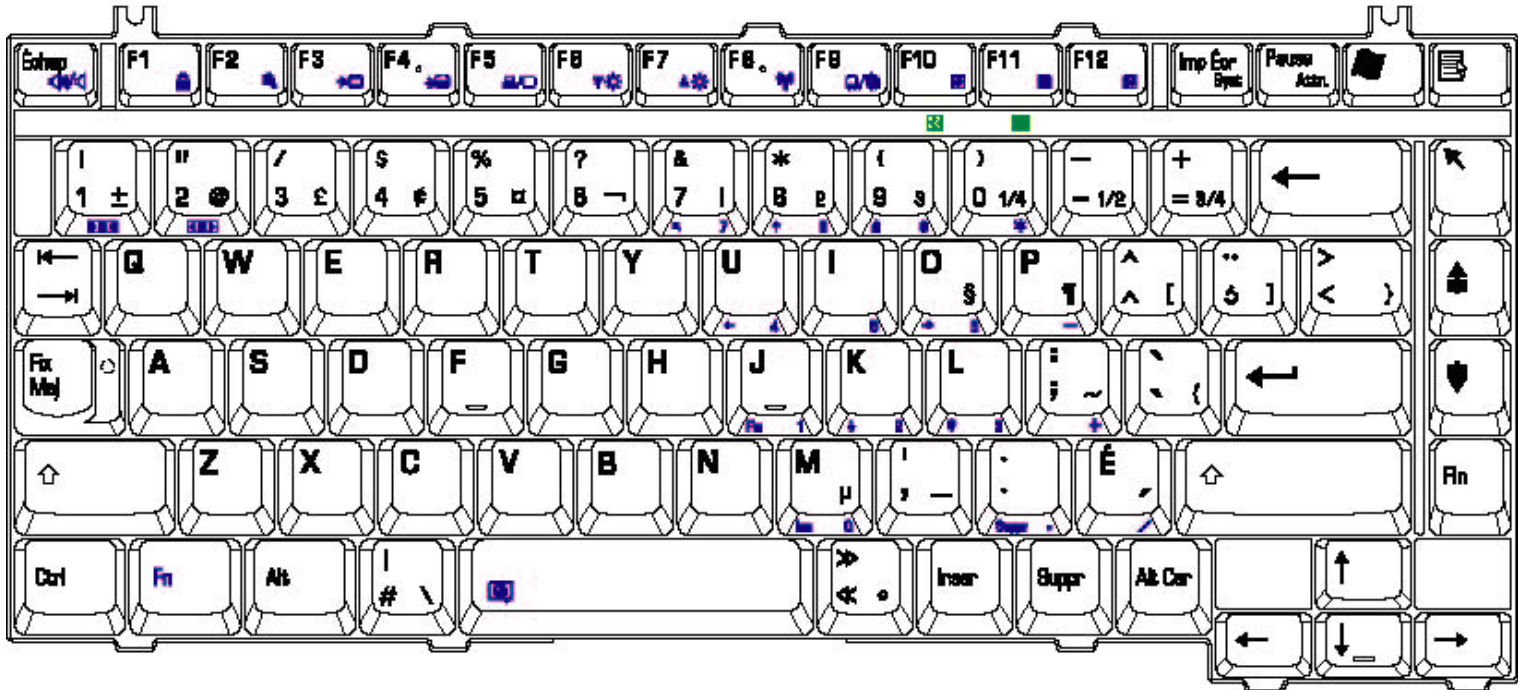

Figure E-6 CF keyboard

E.7 Portuguese (PO) Keyboard

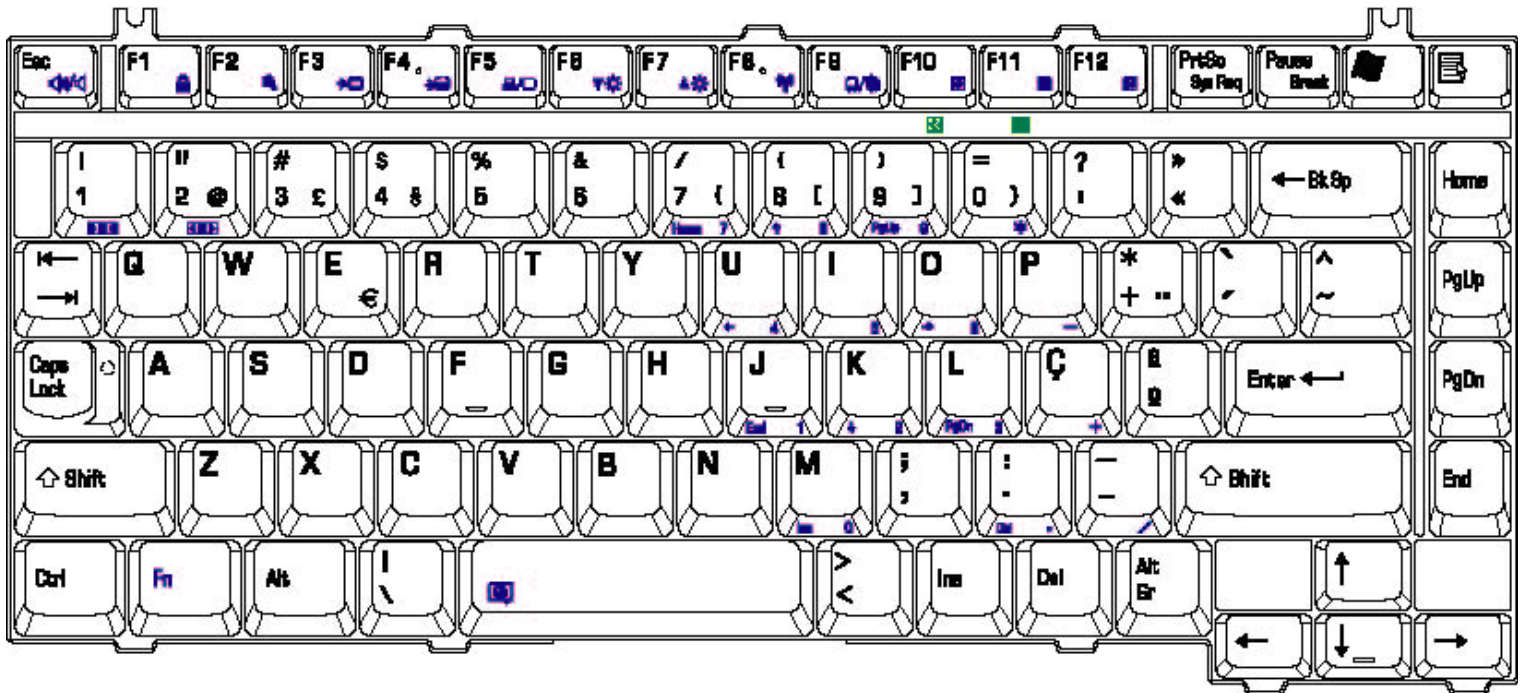

Figure E-7 PO keyboard

E.8 US-INTE (UI/INTE) Keyboard

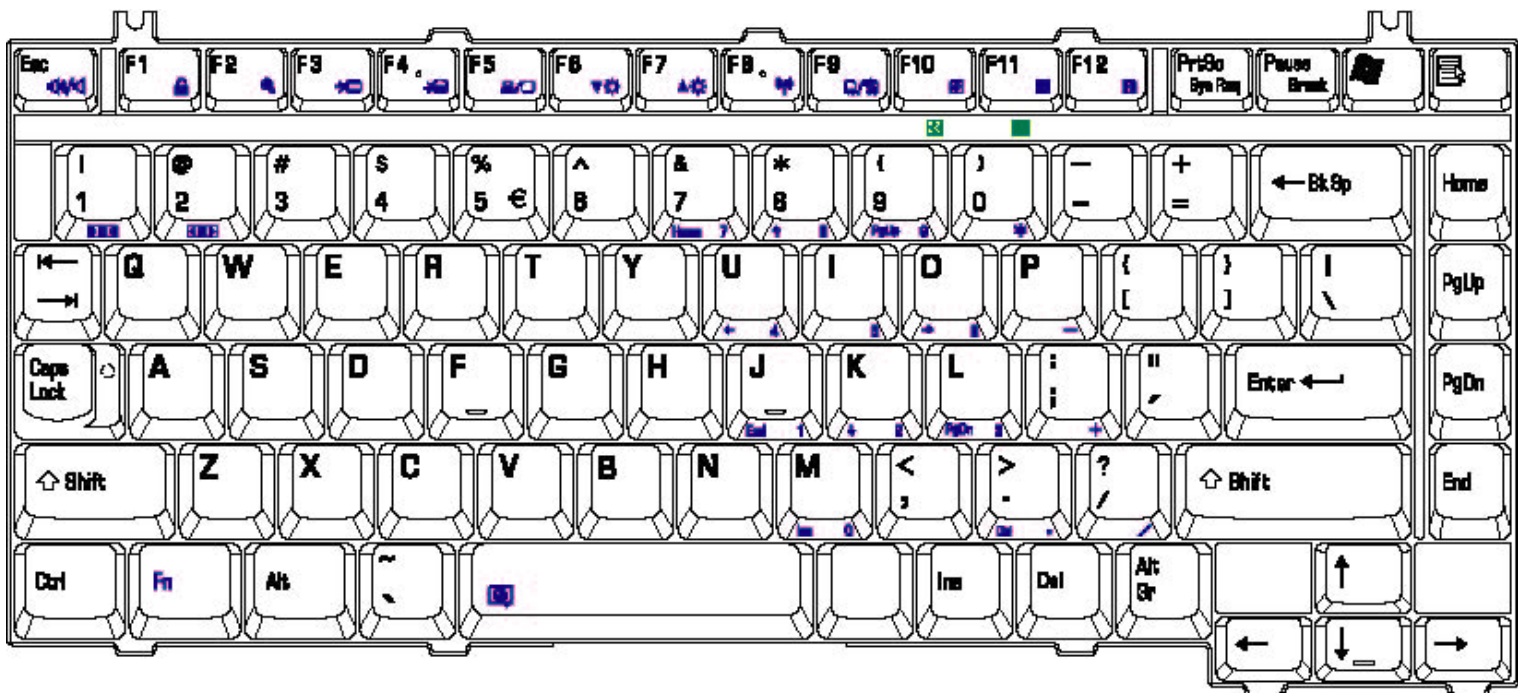

Figure E-8 US-INTE_ALPS Keyboard

E.9 Germanic (GR) Keyboard

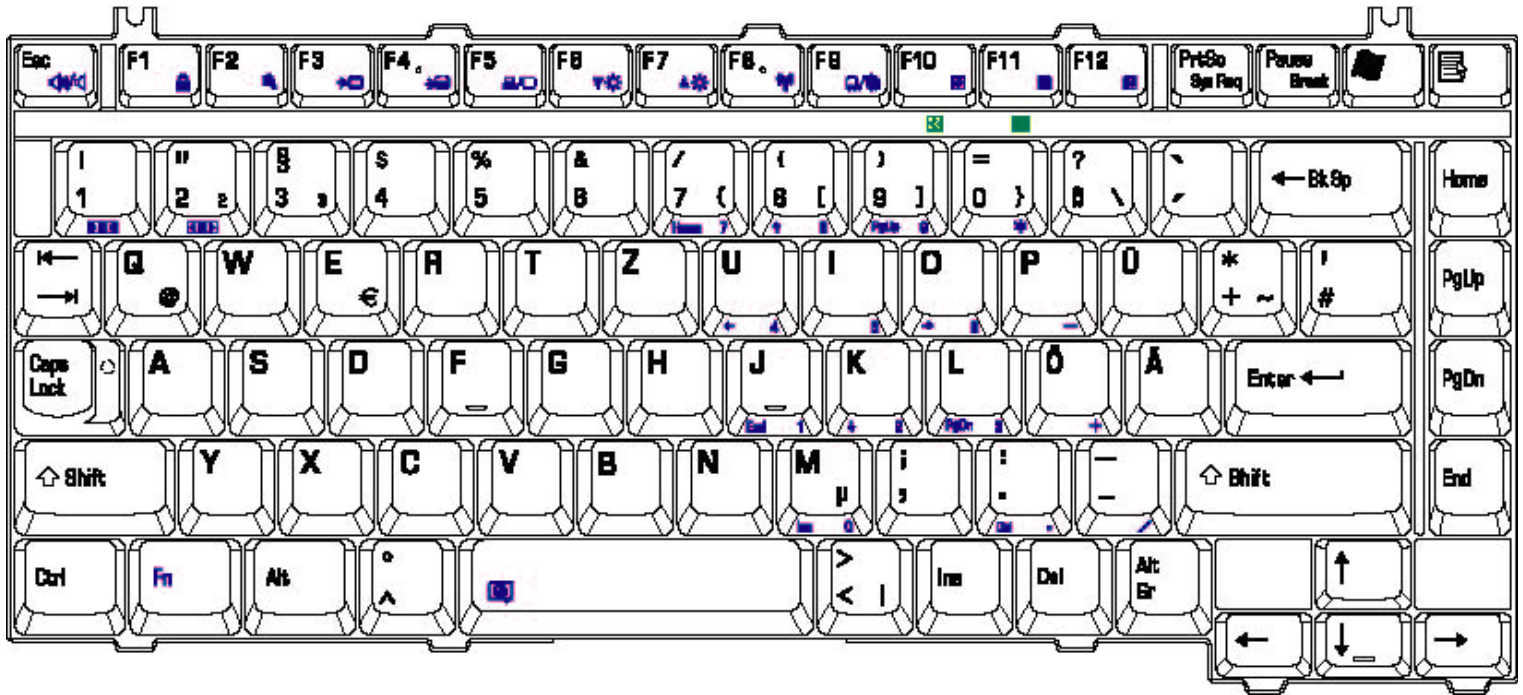

Figure E-9 GR keyboard

E.10 France (FR) Keyboard

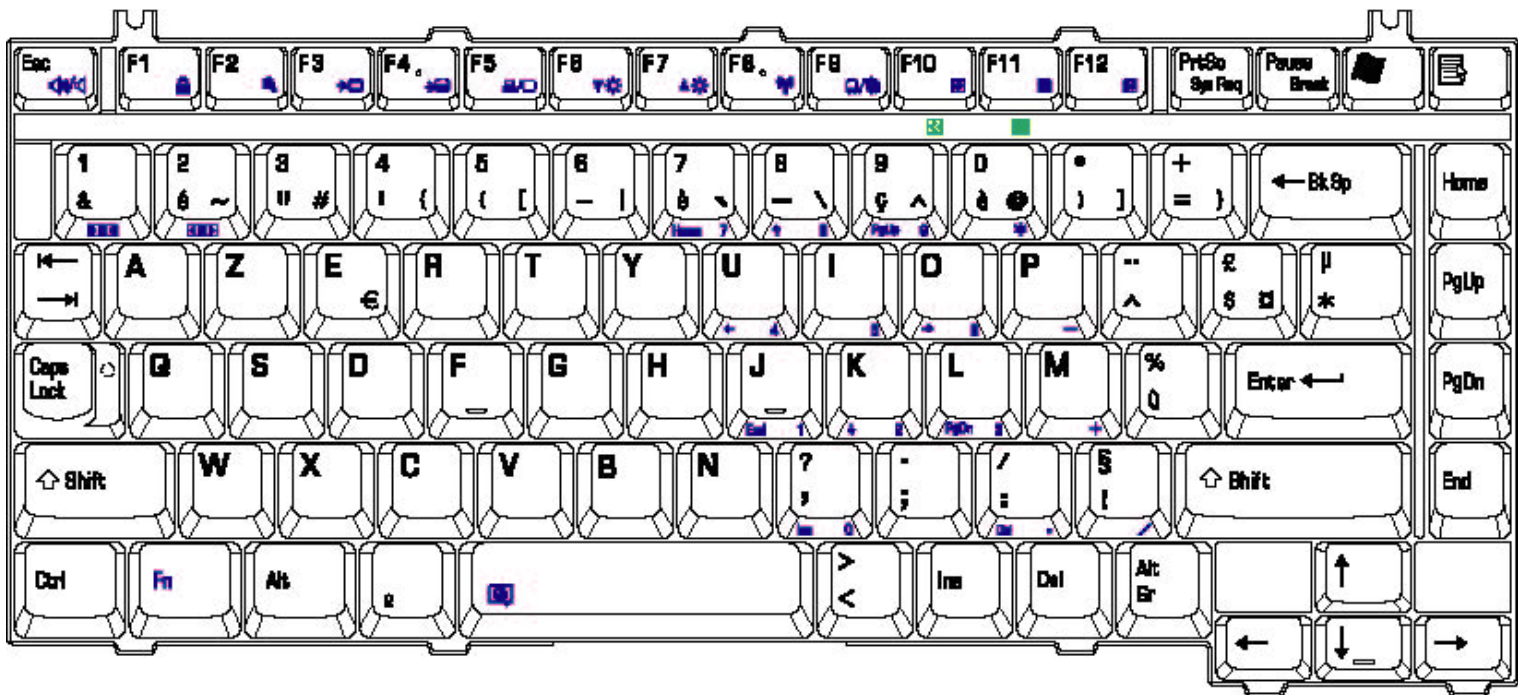

Figure E-10 FR keyboard

E.11 Chinese (CH) Keyboard

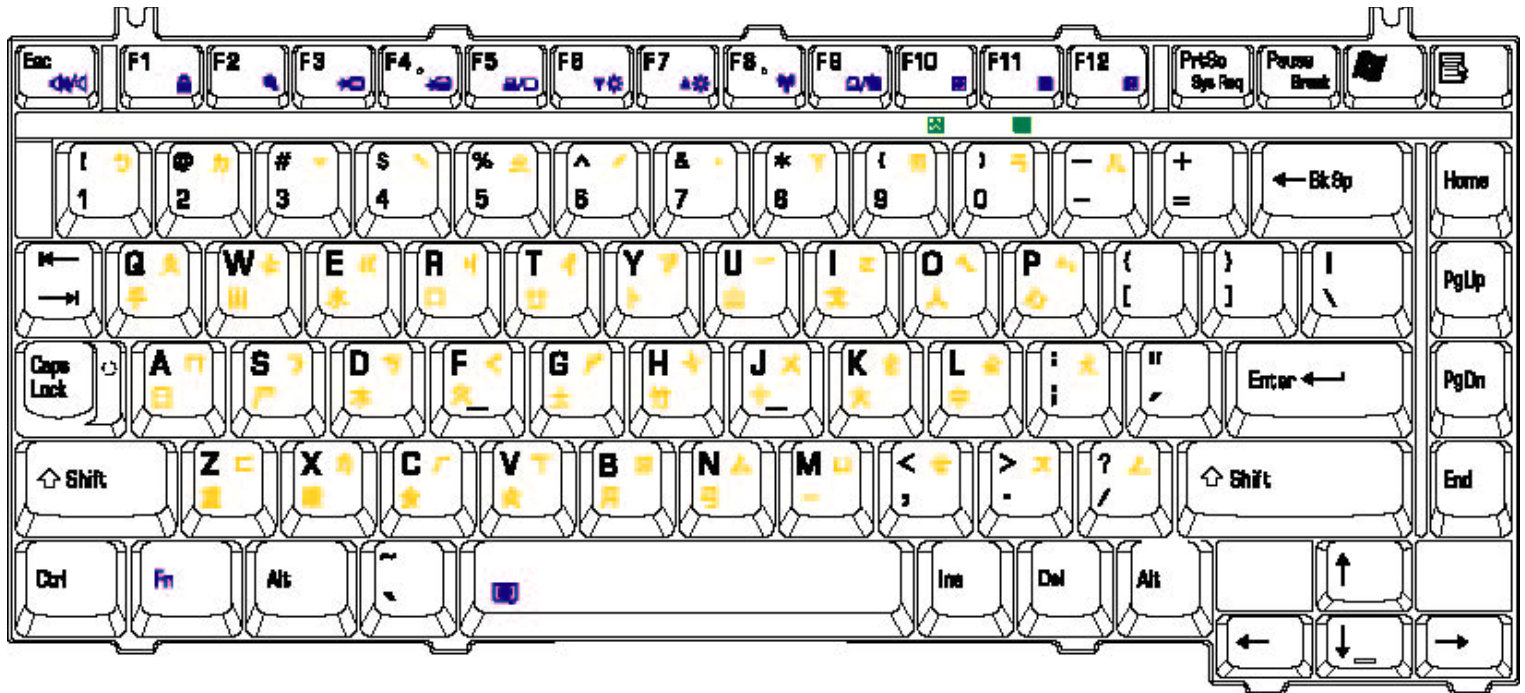

Figure E-11 CH keyboard

E.12 Swissc-Darfon(SG) Keyboard

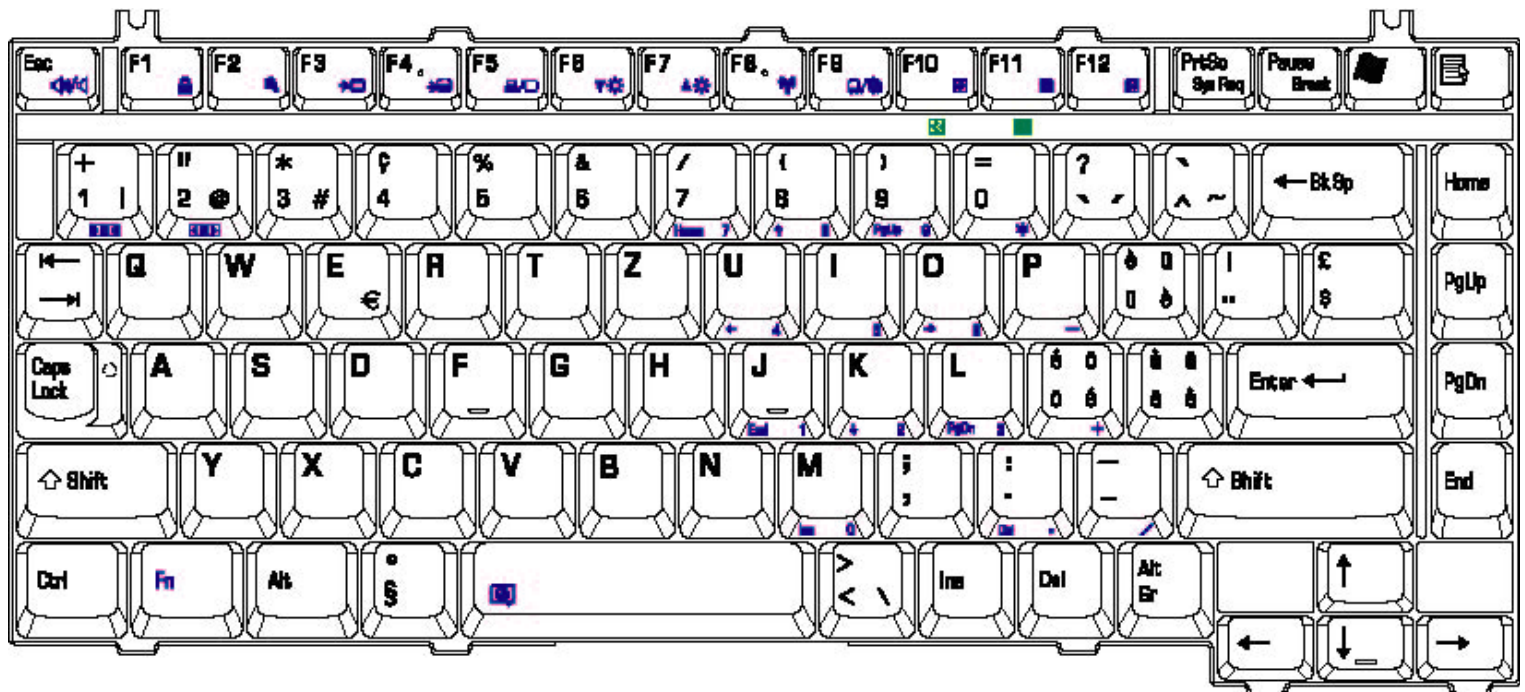

Figure E-12 Swissc-Darfon keyboard

E.13 Italian (IT) Keyboard

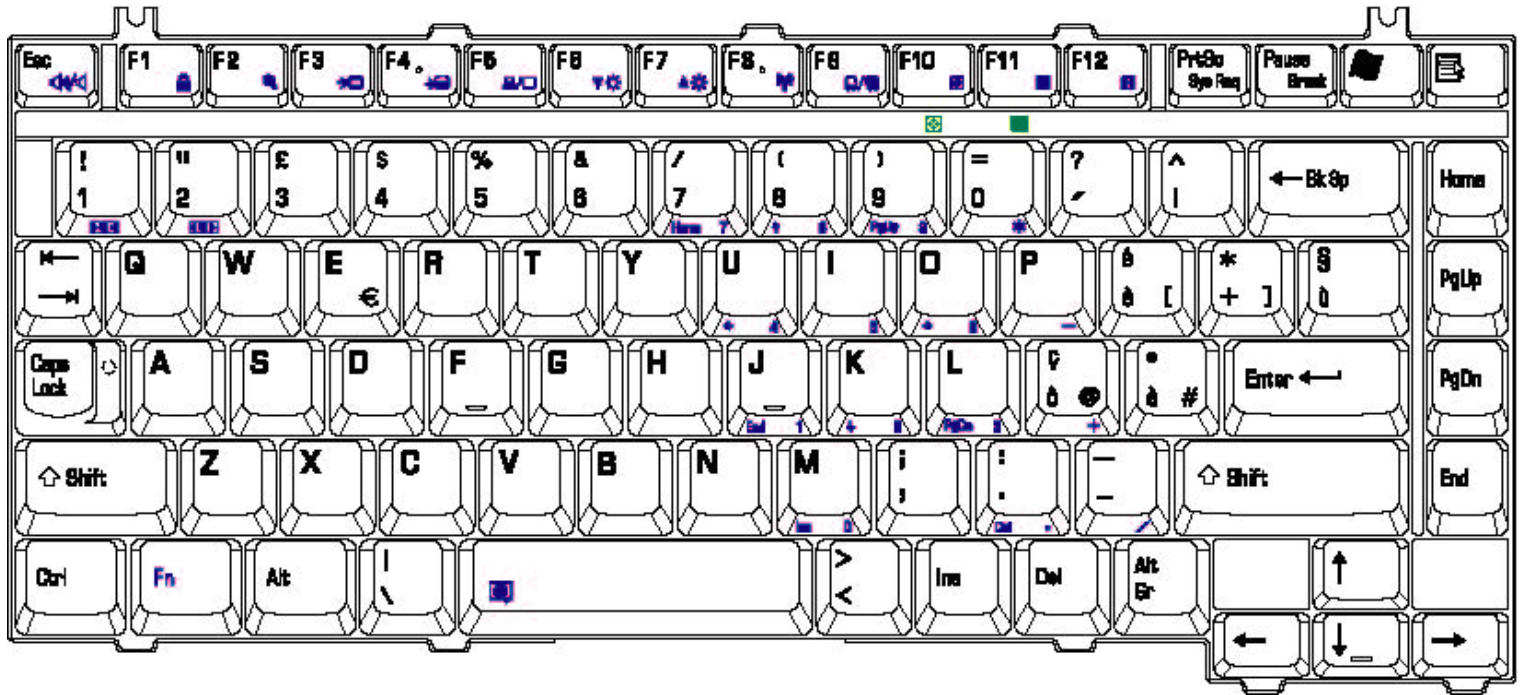

Figure E-13 IT keyboard

E.14 Belgium (BE) Keyboard

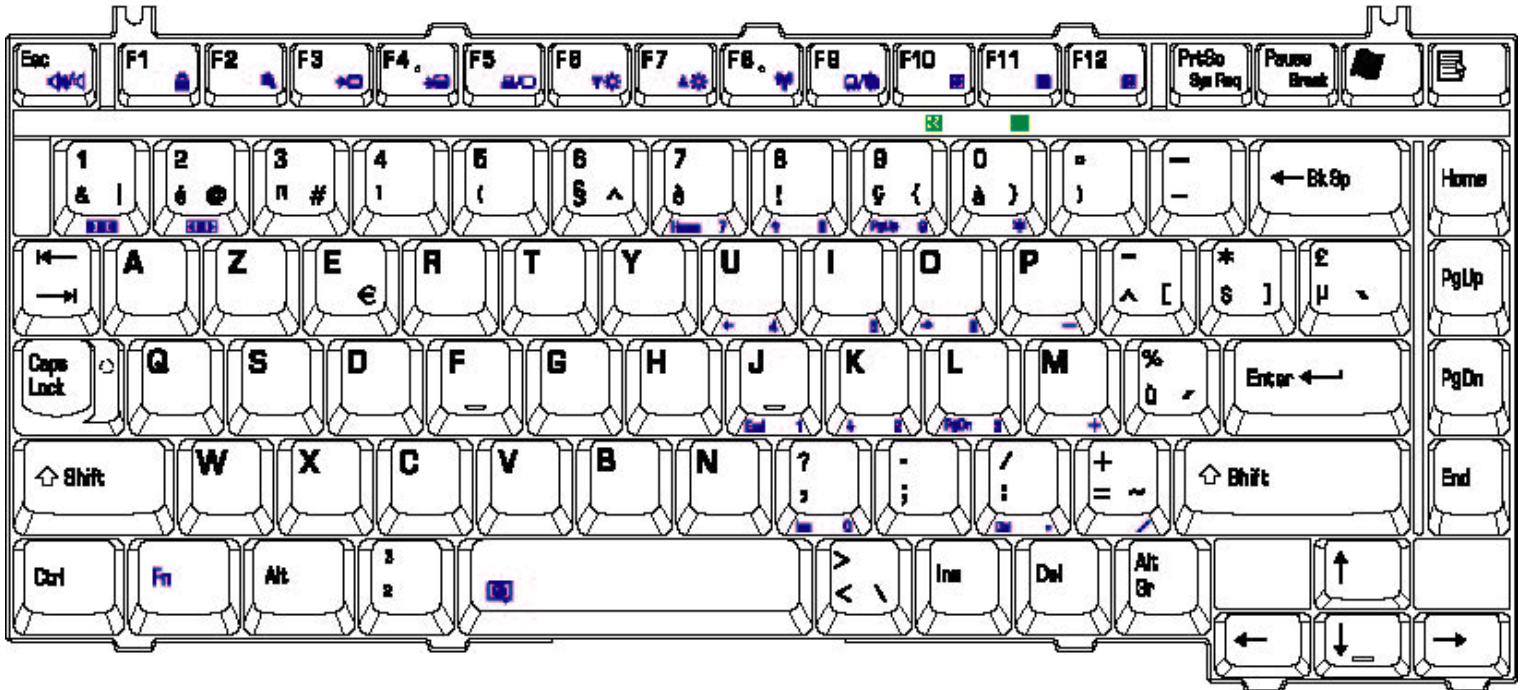

Figure E-14 BE keyboard

E.15 Arabic (AR-E) Keyboard

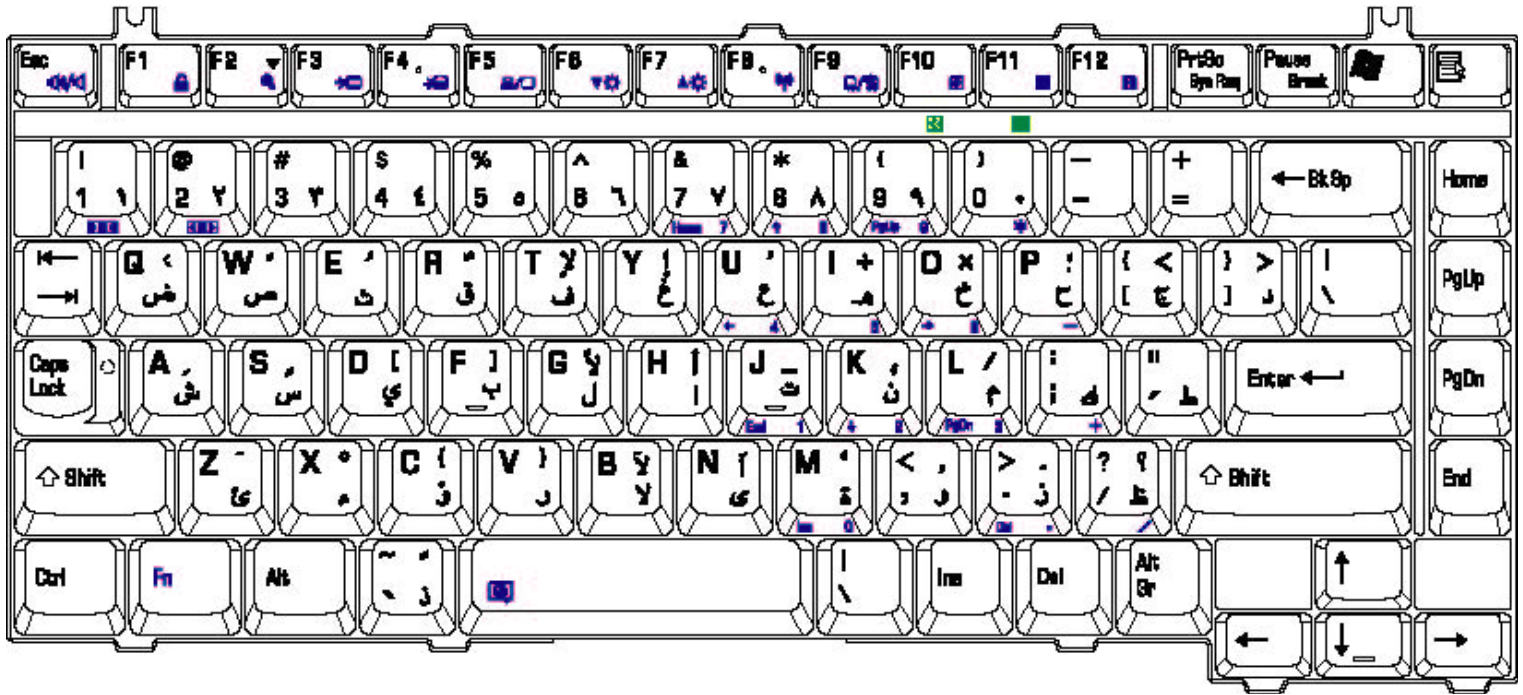

Figure E-15 AR-E keyboard

E.16 Czech (CZ) Keyboard

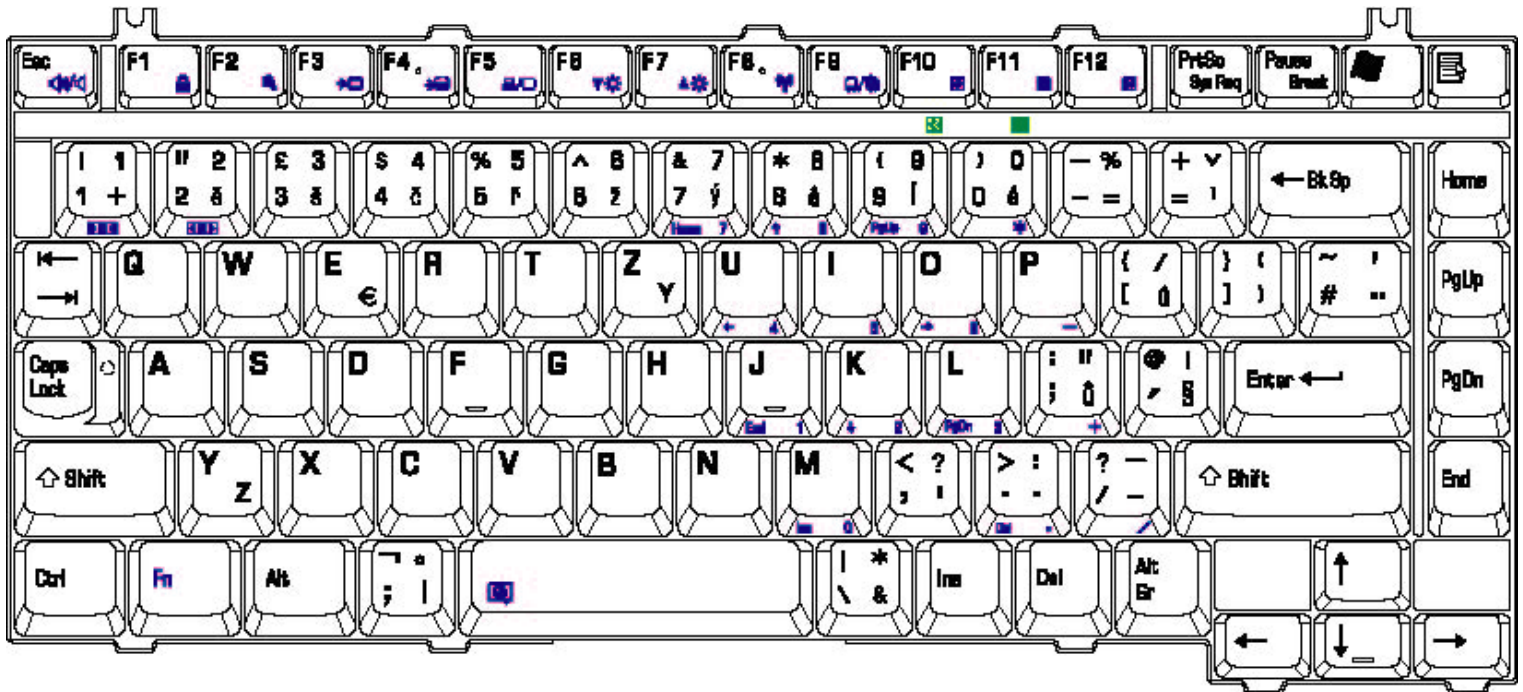

Figure E-16 CZ keyboard

E.17 Estonian (EST) Keyboard

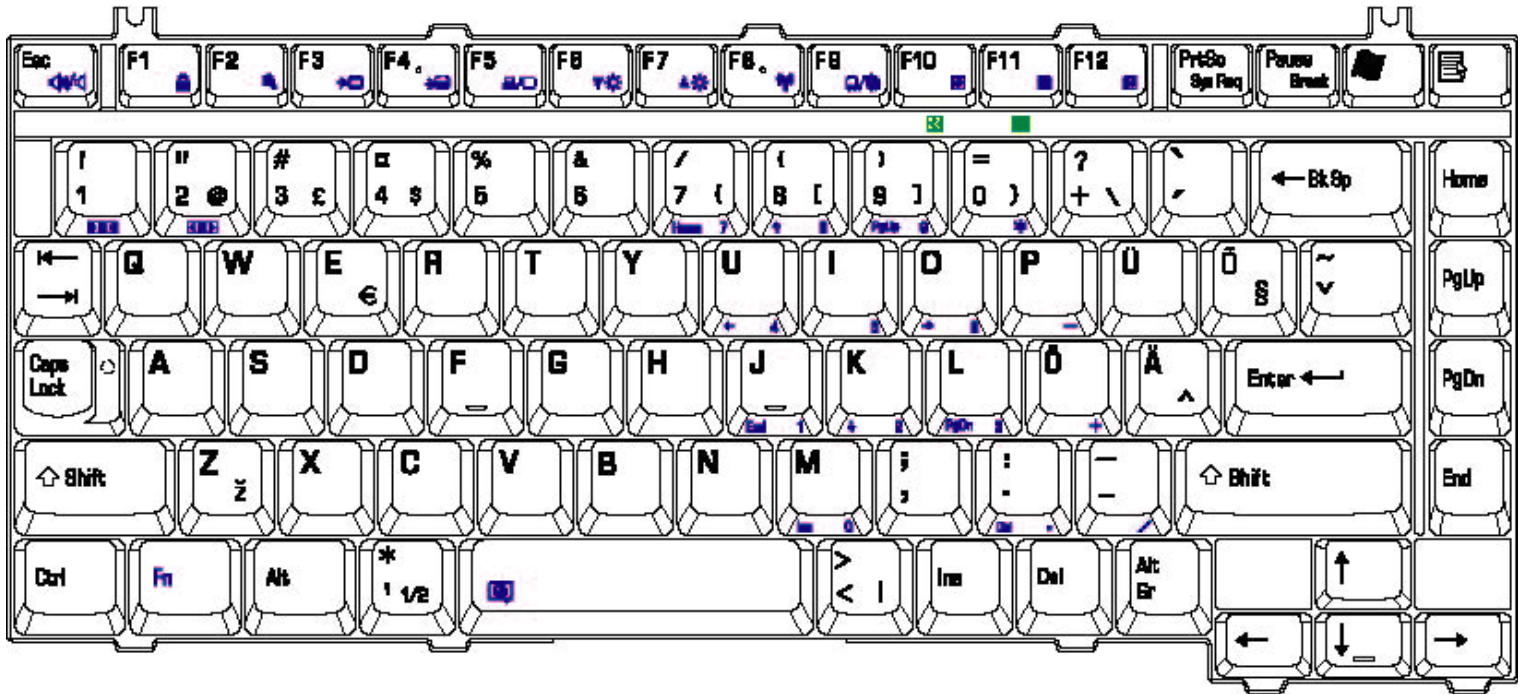

Figure E-17 EST keyboard

E.18 Greek (GK) Keyboard

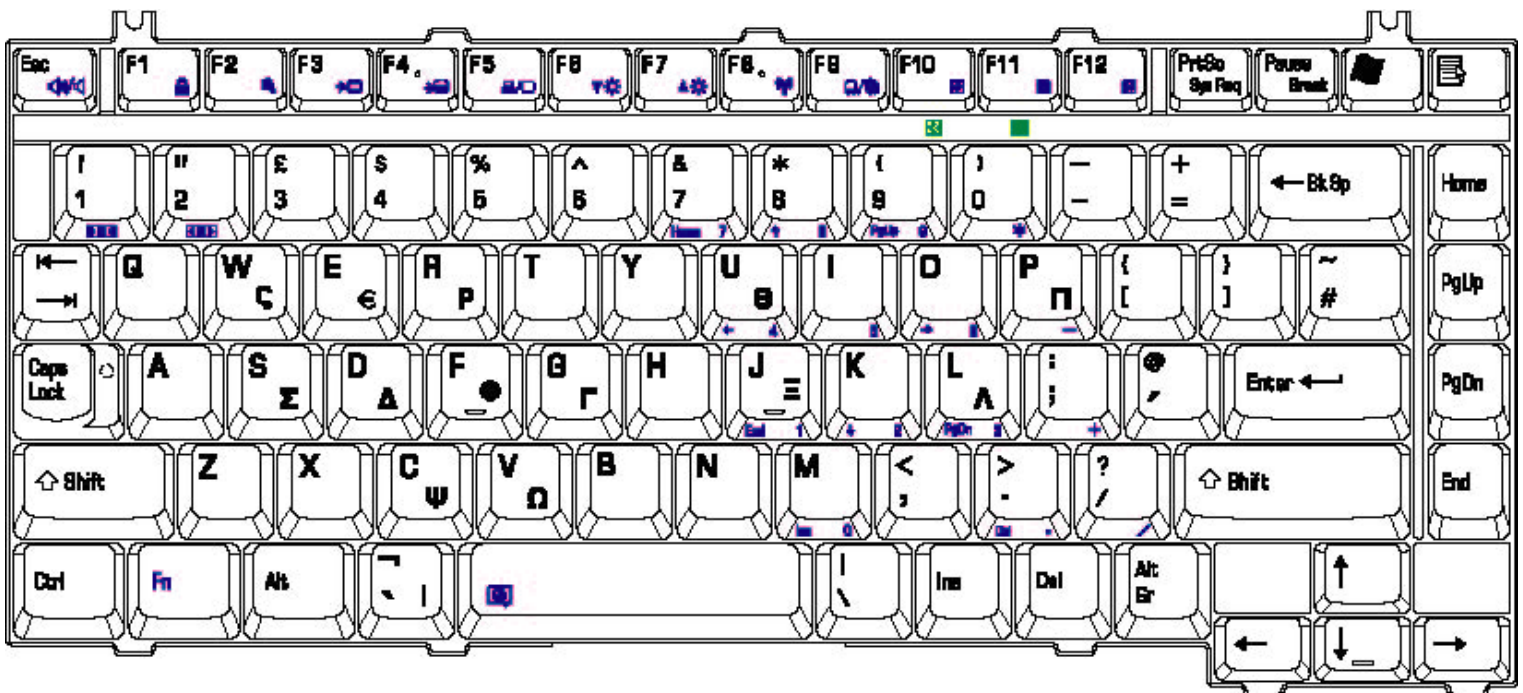

Figure E-18 GK keyboard

E.19 Hebrew (HB) Keyboard

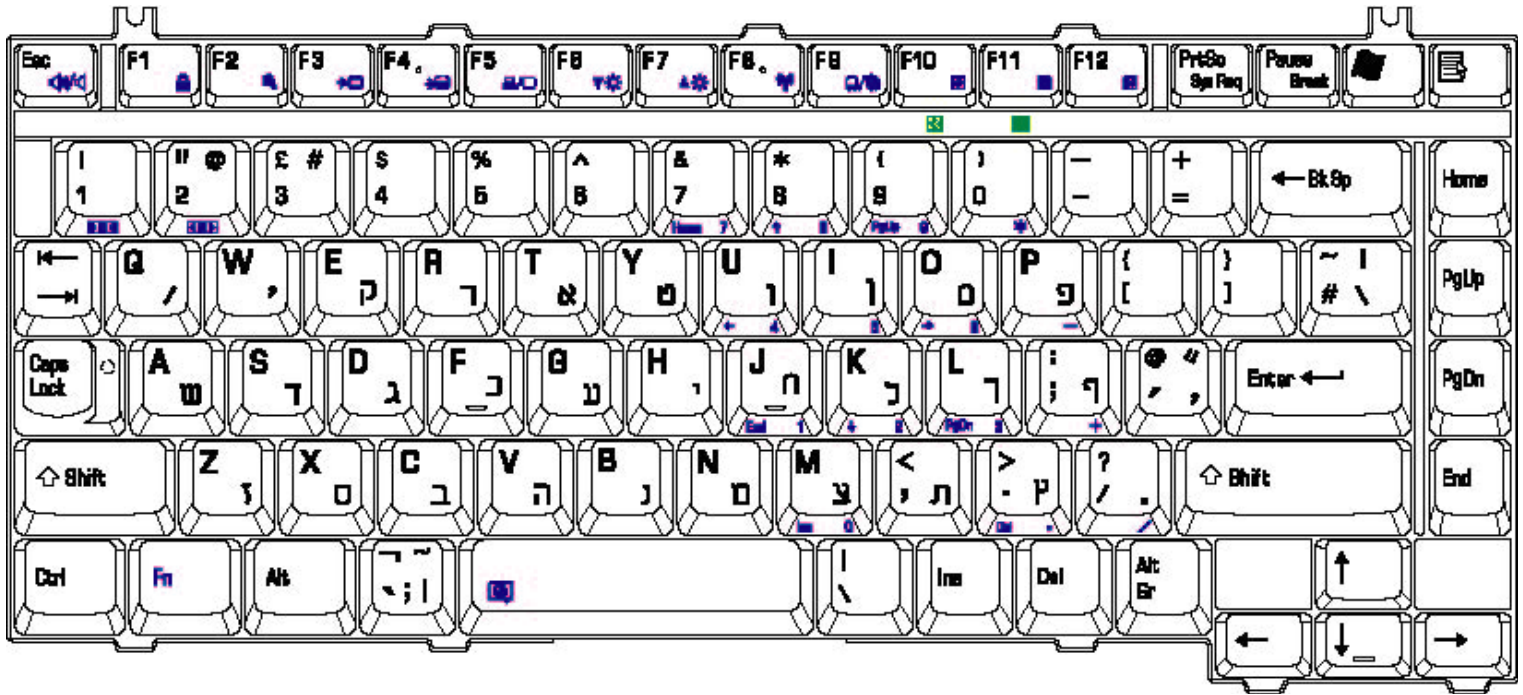

Figure E-19 HB keyboard

E.20 Hungary (HG) Keyboard

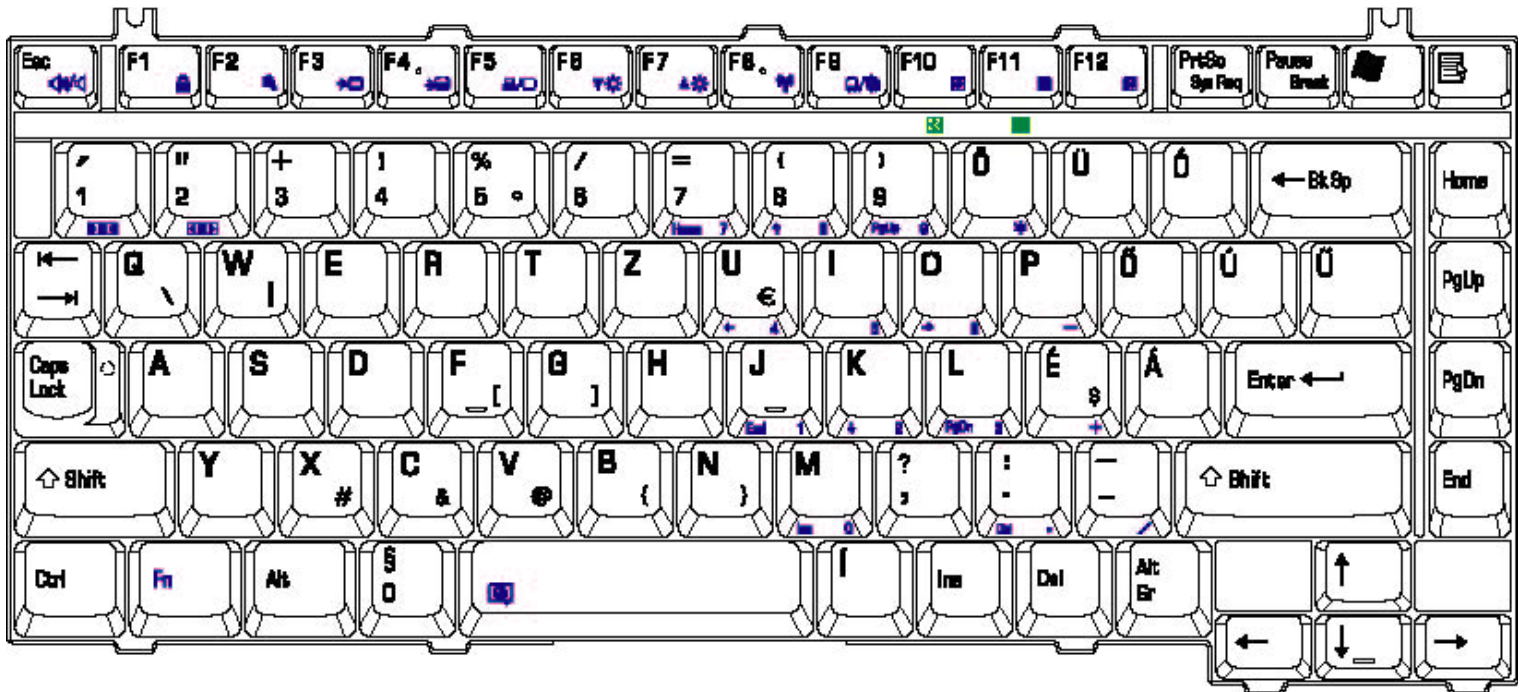

Figure E-20 HG Keyboard

E.21 Norwegian (NW) Keyboard

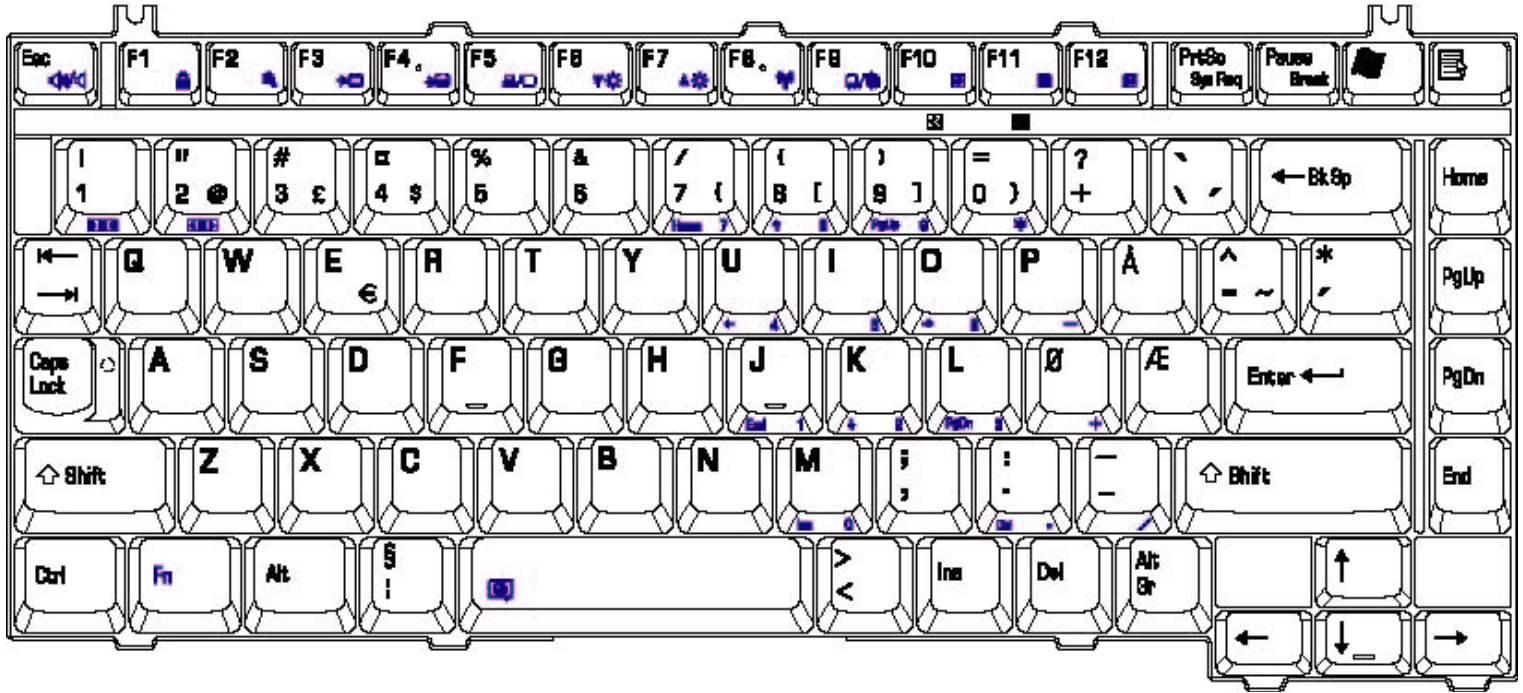

Figure E-21 NW keyboard

E.22 Dutch (DT) Keyboard

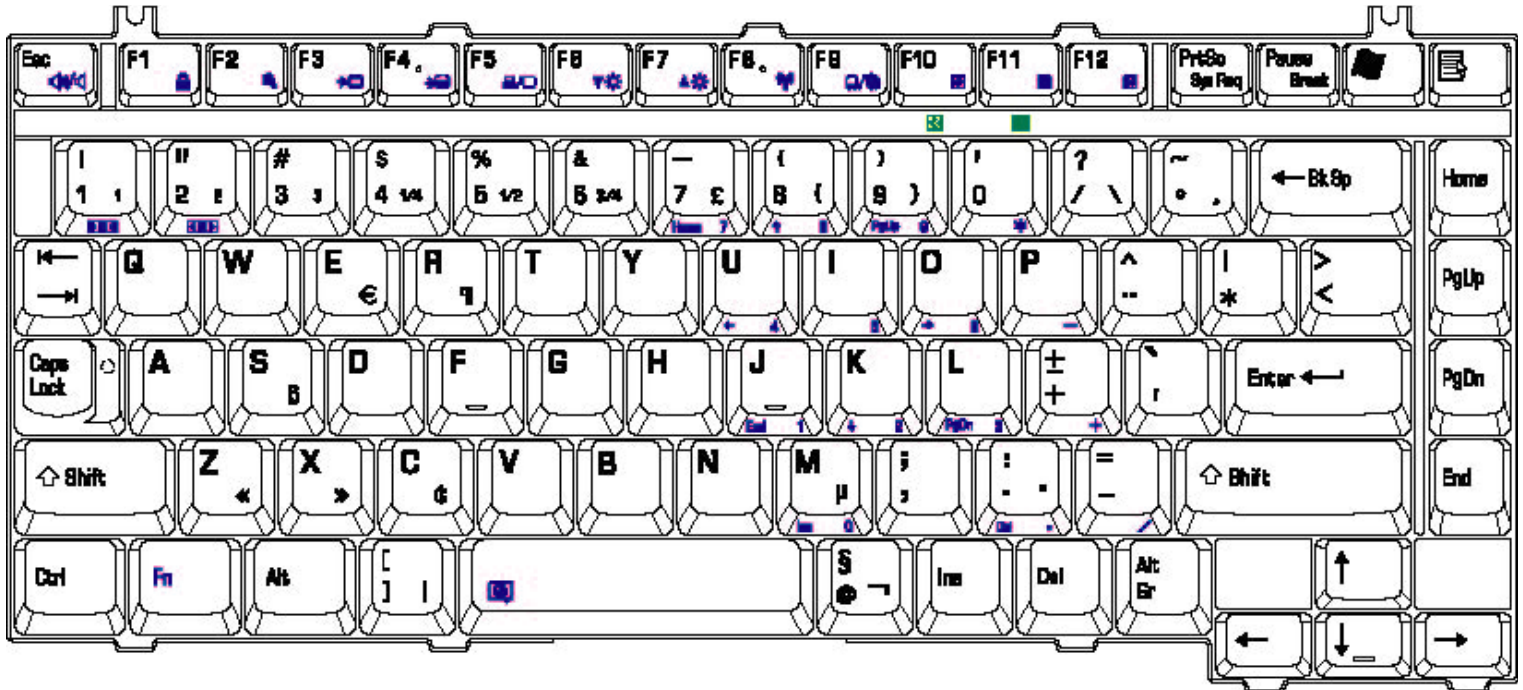

Figure E-22 DT keyboard

E.23 Lithuanian (LIT) Keyboard

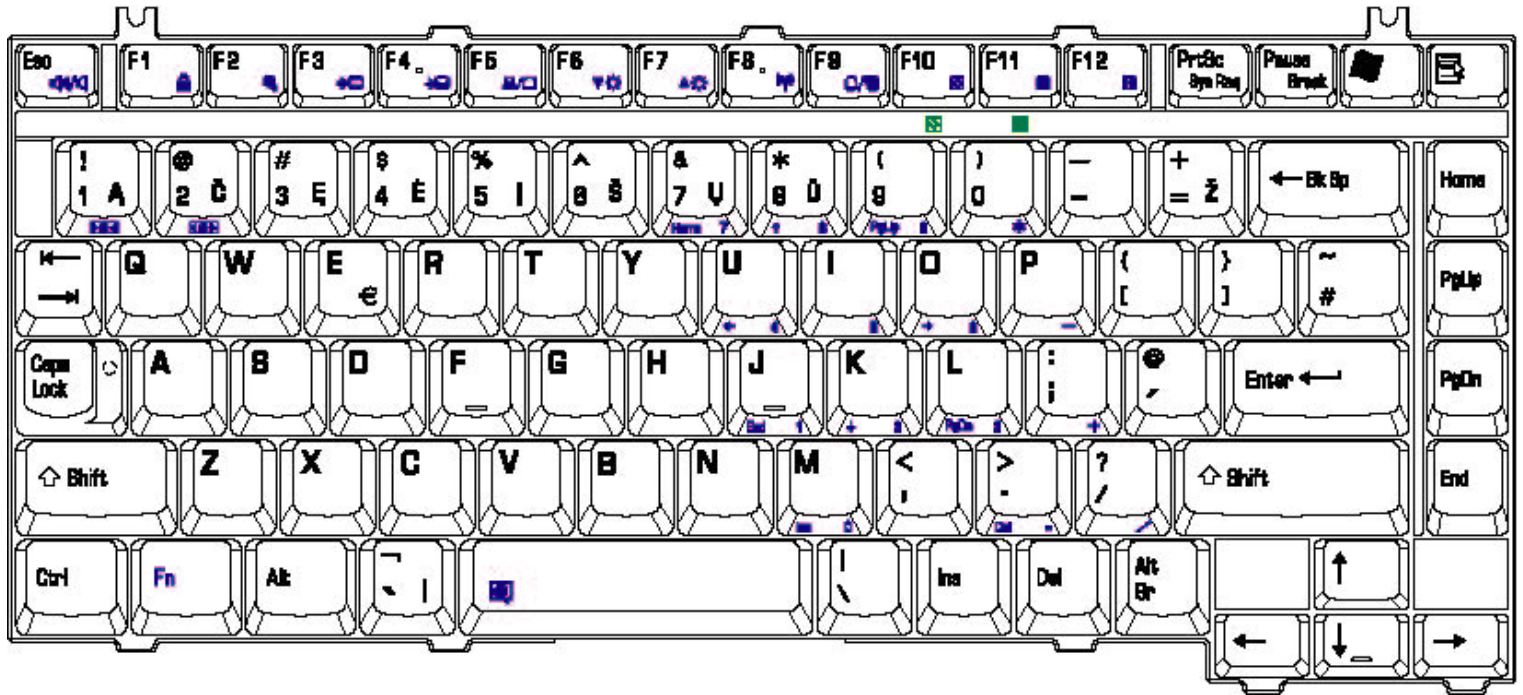

Figure E-23 LIT keyboard

E.24 Russian (RU) Keyboard

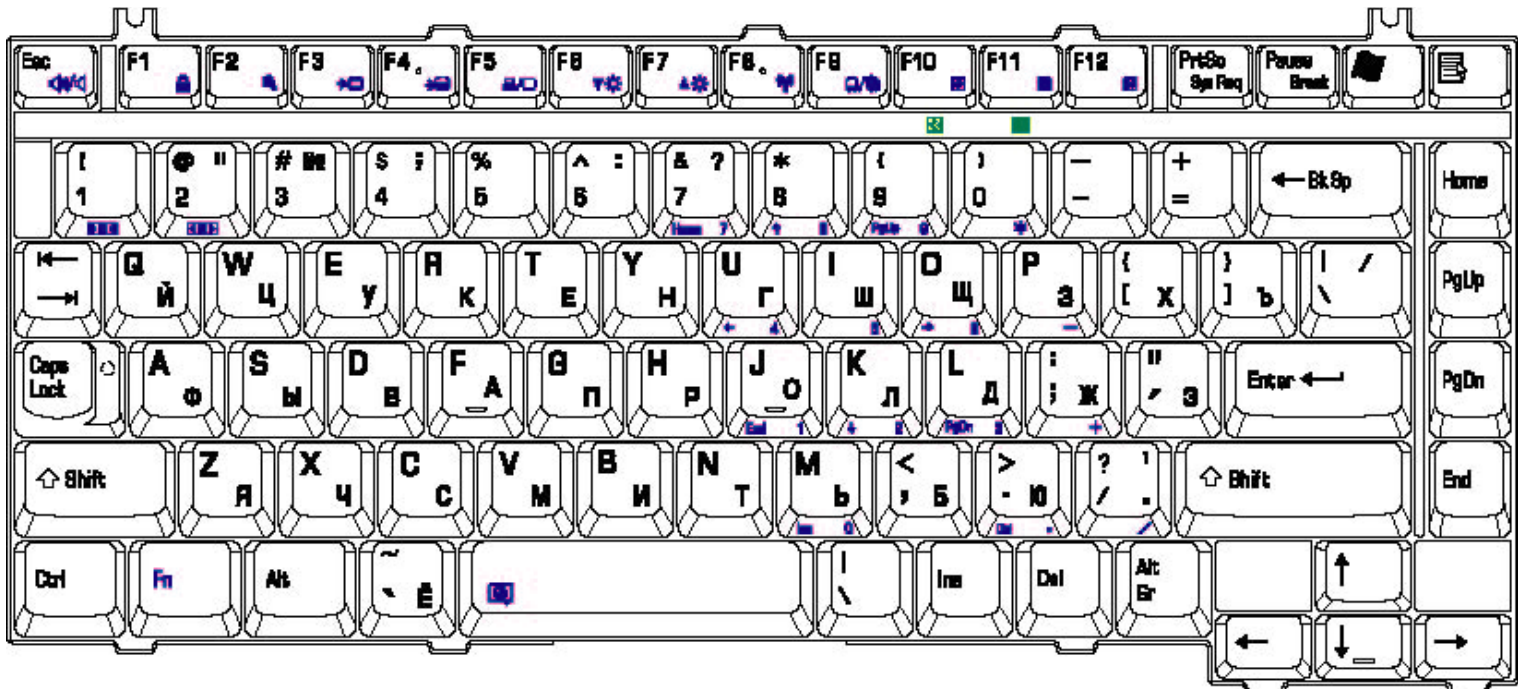

Figure E-24 RU keyboard

E.25 Turkish (TR) Keyboard

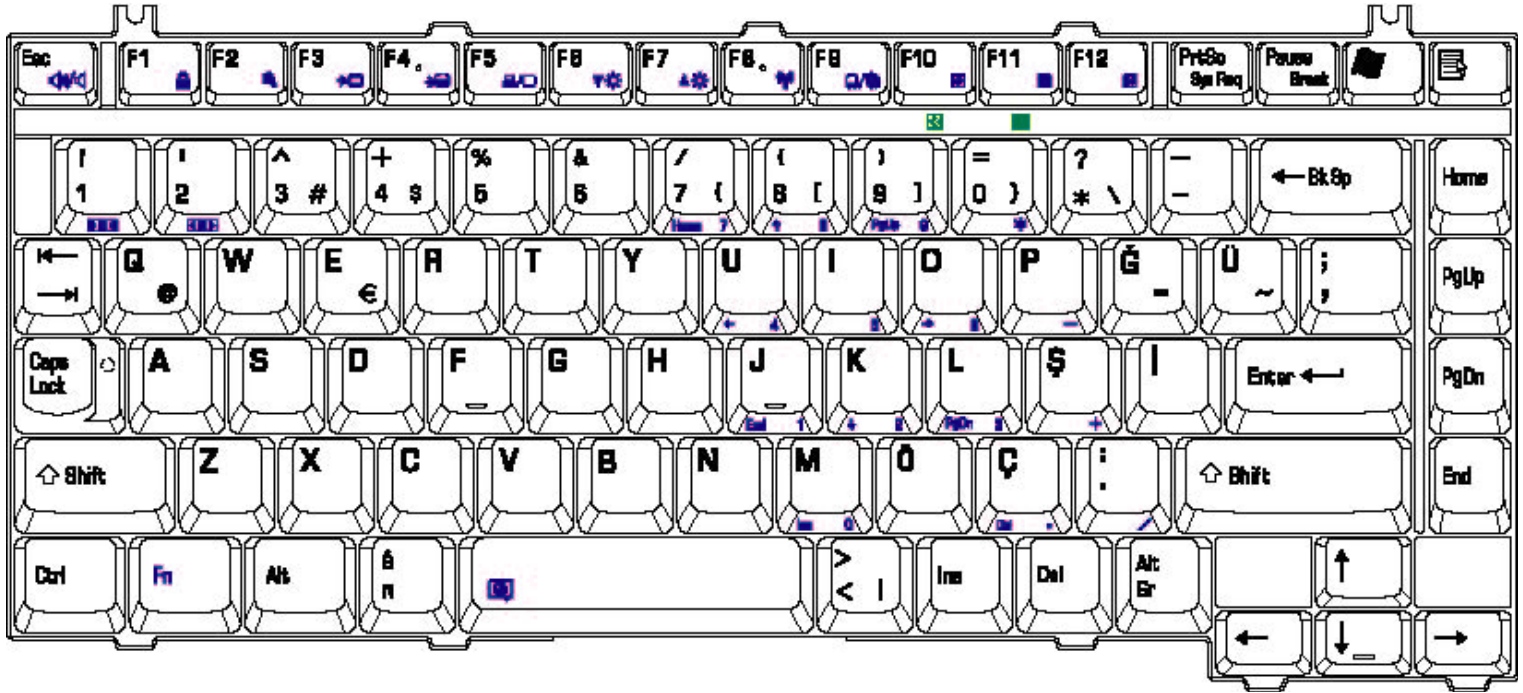

Figure E-25 TR keyboard

E.26 Yugoslavian (YU) Keyboard

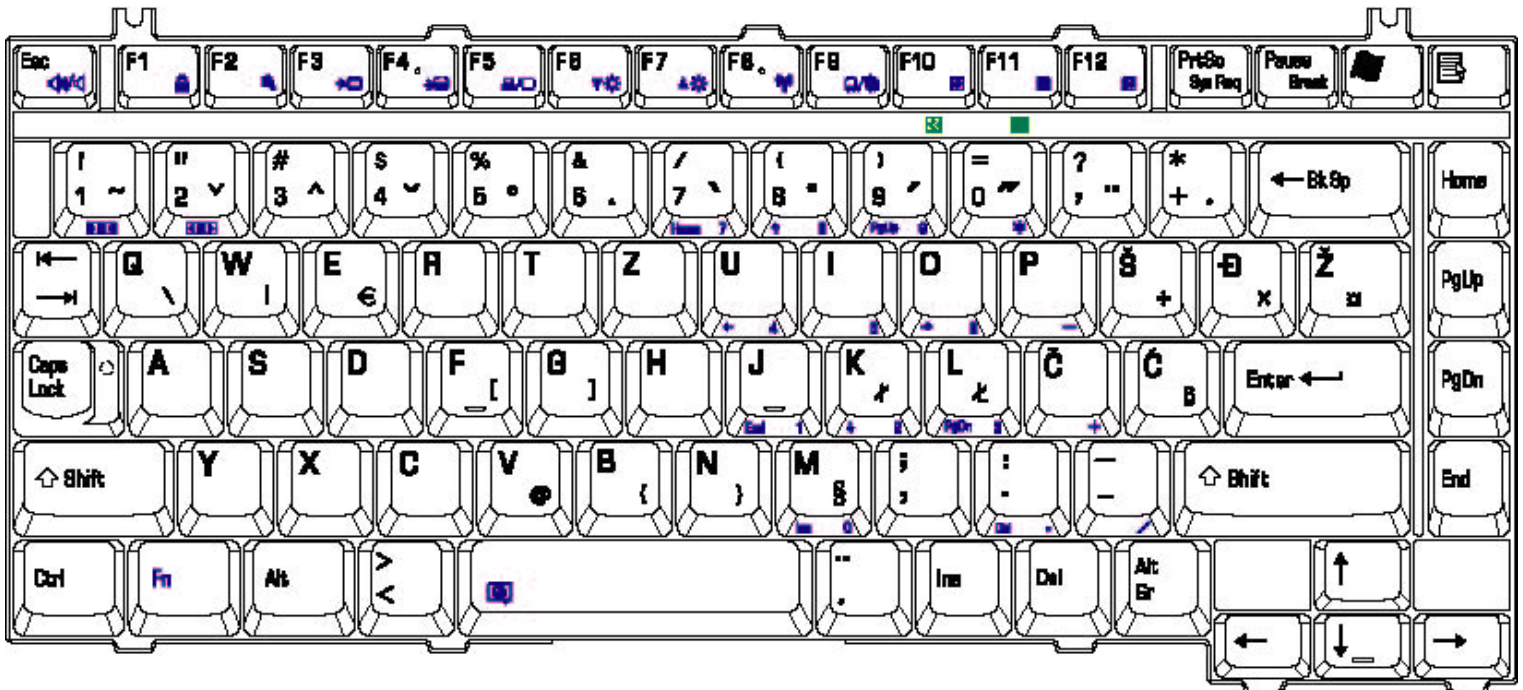

Figure E-26 YU keyboard

E.27 Danish (DM) Keyboard

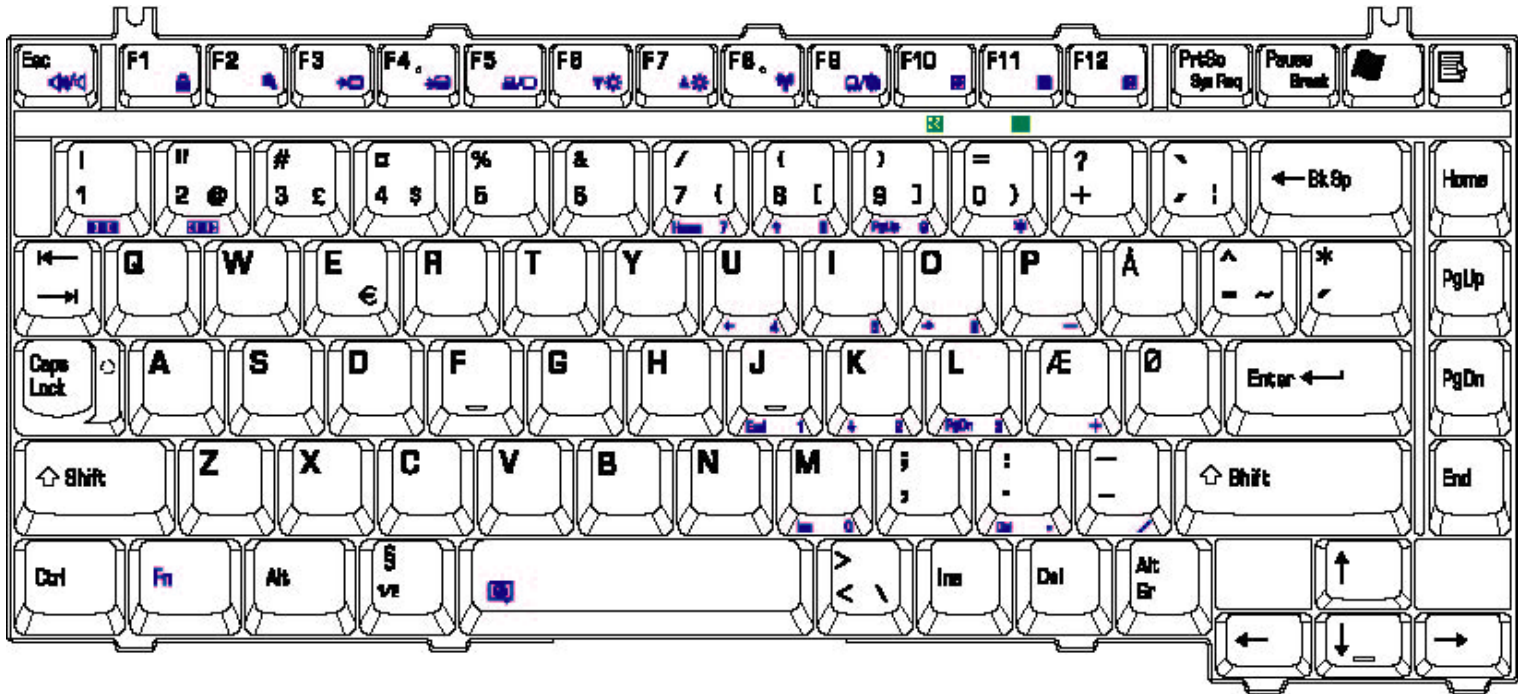

Figure E-27 DM keyboard

E.28 Slovak (SA) Keyboard

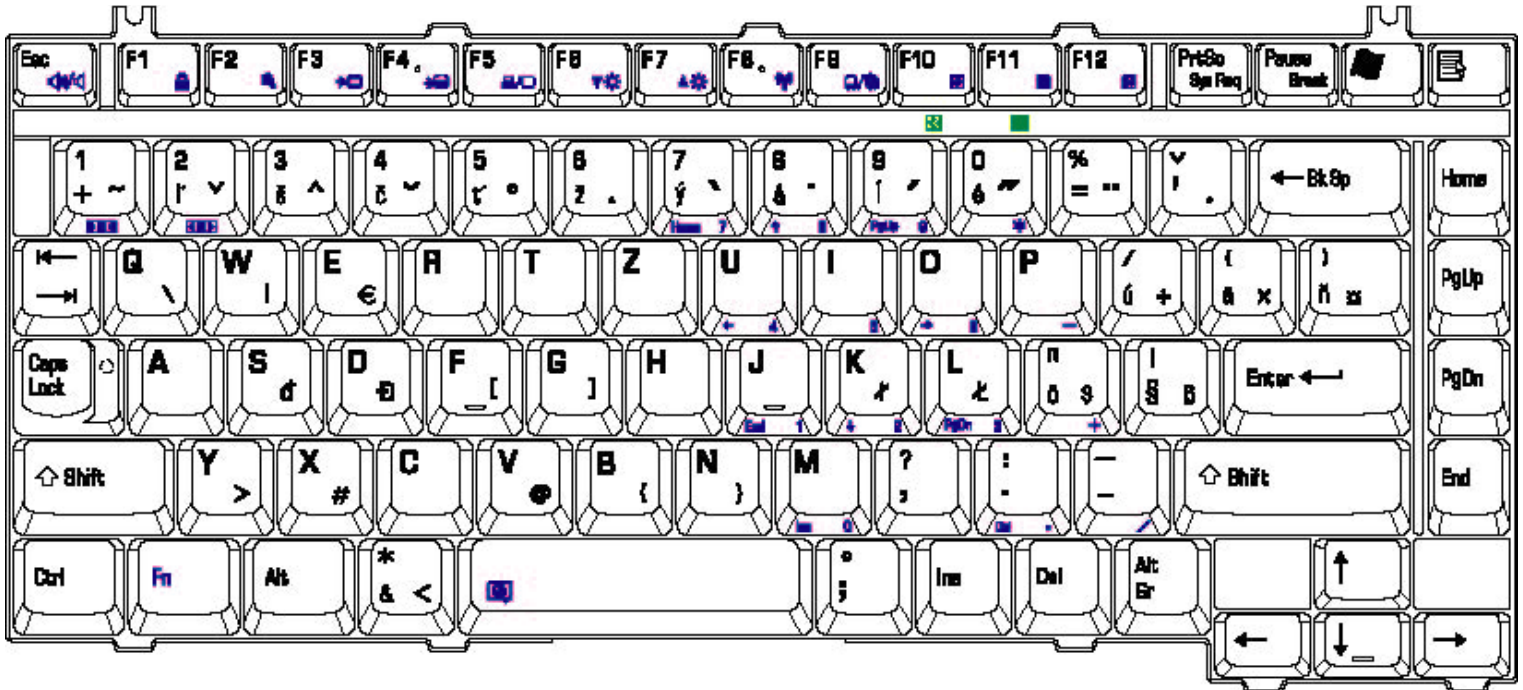

Figure E-28 SR keyboard

E.29 Slovak (SA) Keyboard

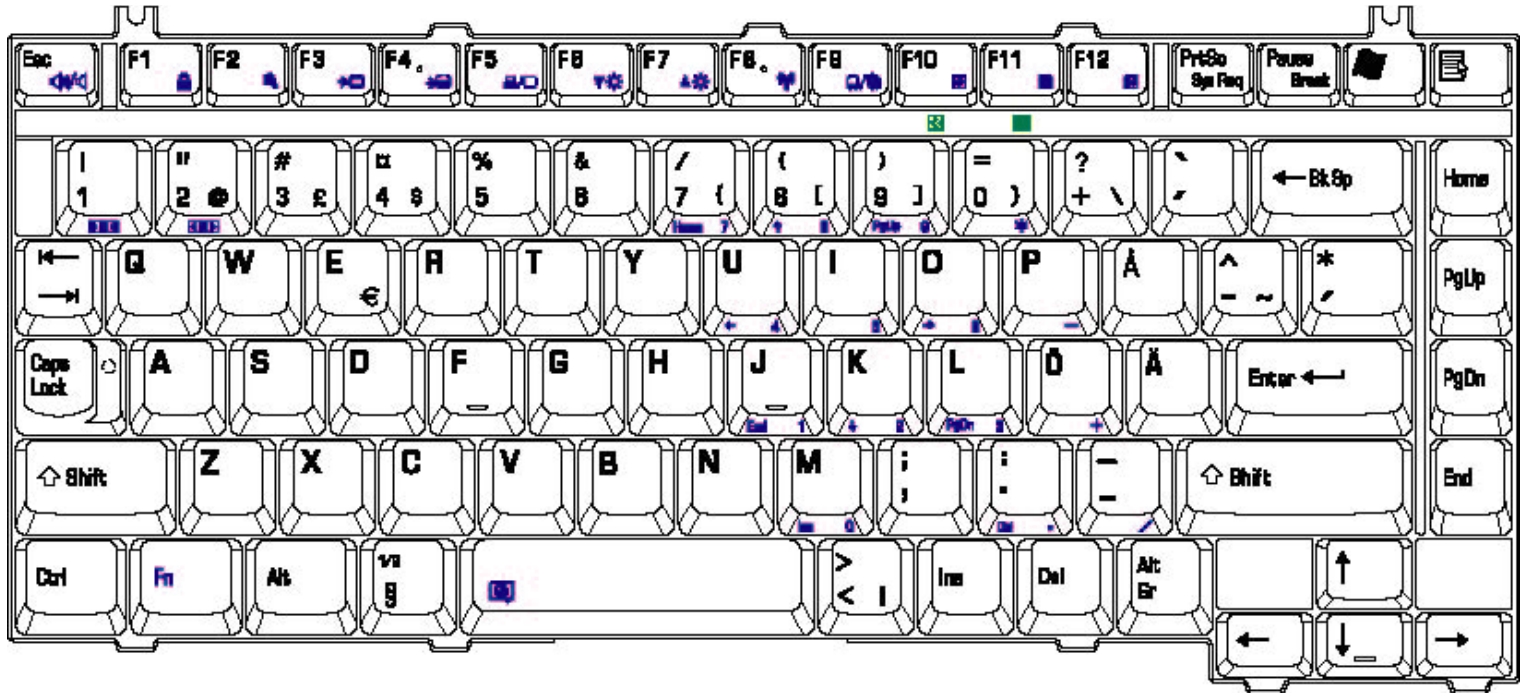

Figure E-29 SD keyboard

Appendix F Series Screw Torque List

Table F-1 Series Screw Torque List

SCREW P/N	SCREW SPEC	Q'ty	LOCATION	SCREW TORQUE
LCD ASSY				
MMCK25050Z0	M2.5*5	4	LCD BRACKET ASSY (R/L) TO COVER SUB ASSY	2.5~3.0kg
MMCK20030Z0	M2.0*3	8	LCD BRK TO LCD PANEL (15")	2.0~2.5kg
MMCK20030Z0	M2.0*3	1	INVERTER TO COVER SUB ASSY	2.0~2.5kg
MMCK20030Z0	M2.0*3	1	LCD CABLE TO COVER	2.0~2.5kg
MB ASSY				
MM000000100	M2.0*4	4	PCMCIA TO MB	1.5~2.0kg
MM000000100	M2.0*4	2	BATT CONN TO MB	1.5~2.0kg
MM000000100	M2.0*4	2	MB TO CD ROM CONN.(FIX BAY)	1.5~2.0kg
MM000000100	M2.0*4	2	NB SINK BRKT	1.5~2.0kg
HDD ASSY				
MAAA4303000	JMK 3.0*3	4	HDD BRACKET TO HDD	3.0~3.5kg
LOG UPPER SUB ASSY				
MMCK25050Z0	M2.5*5	2	HINGE SADDLE(R) TO TOP SHIELD BATT TO LOG UP	2.5~3.0kg
LOG UPPER ASSY				
MMCK25030Z0	M2.5*3	1	TP BRK TO LOG UP	2.5~3.0kg
MMCK25030Z0	M2.5*3	1	SPEAKER R/L TO LOG UP	2.5~3.0kg
MMCK25030Z0	M2.5*3	1	TP PCB TO LOG UP	2.5~3.0kg
MMCK25030Z0	M2.5*3	1	POWER PCB TO LU	2.5~3.0kg

SCREW P/N	SCREW SPEC	Q'ty	LOCATION	SCREW TORQUE
LOGIC ASSY				
MACK25080Z0	M2.5*8	1	LOG LOW TO HINGE SADDLE R TO LOG UP	2.5~3.0kg
MACK25080Z0	M2.5*8	1	LL TO LL SHIELD TO MB TO LU	2.5~3.0kg
MACK25080Z0	M2.5*8	1	LL TO LL SHIELD MB STANDOFF TO HINGE SADDLE TO LU	2.5~3.0kg
MACK25080Z0	M2.5*8	1	LL TO LL SHIELD TO HINGE SADDLE TO LU	2.5~3.0kg
MACK25080Z0	M2.5*8	1	LL TO LL SHIELD HINGE SADDLE TO LU	2.5~3.0kg
MACK25080Z0	M2.5*8	2	LL TO LL HDD SHIELD TO VR_USB_BOARD TO LU	2.5~3.0kg
MACK25080Z0	M2.5*8	2	LL TO LCD SADDLE TO HINGE SADDLE	2.5~3.0kg
MACK25080Z0	M2.5*8	2	LCD SADDLE TO LU TO HINGE SADDLE	2.5~3.0kg
MMCK25140Z0	M2.5 K 5.5X0.8 14	2	LOG UP TO VGA BOARD TO VGA BOARD STANDOFF TO MB LOG LOW	2.5~3.0kg
MMCK25140Z0	M2.5K 5.5*0.8	2	LOG UP TO MB TO LOG LOW	2.5~3.0kg
MMCK25050Z0	M2.5*5	3	VGA THERMAL SINK TO VGA BOARD	2.5~3.0kg
MMCK25050Z0	M2.5*5	1	LOG UP TO VGA BOARD TO VGA BOARD STANDOFF	2.5~3.0kg
MMCK25050Z0	M2.5*5	1	LOG LOW TO LOG LOW SHIELD TO HINGE SADDLE R	2.5~3.0kg
MMCK25050Z0	M2.5*5	1	LL TO FIX BAT BRK	2.5~3.0kg
MMCK25050Z0	M2.5*5	1	LL TO MB TO LU	2.5~3.0kg
MMCK25050Z0	M2.5*5	1	LOG LOW TO LOG LOW SHIELD TO HINGE SADDLE L	2.5~3.0kg
MMCK25050Z0	M2.5*5	1	LL TO LL SHIELD TO RJ11/45 PCB TO LU	2.5~3.0kg
MMCK25050Z0	M2.5*5	3	LL TO MB TO LU	2.5~3.0kg
MMCK25050Z0	M2.5*5	1	LL TO MB TO LU	2.5~3.0kg
MMCK25050Z0	M2.5*5	2	THERMAL FAN ASSY TO MB TO LL	2.5~3.0kg
MMCK25050Z0	M2.5*5	1	THERMAL FAN ASSY TO LL	2.5~3.0kg
MMCK25050Z0	M2.5*5	1	LU TO LL	2.5~3.0kg
MMCK25050Z0	M2.5*5	2	HDD DOOR TO LL	2.5~3.0kg
MMCK25050Z0	M2.5*5	4	CPU THERMAL SINK TO CPU STANDOFF	2.5~3.0kg

MMCK25030Z0	M2.5*3	2	KB TO TOP SHIELD BATT TO LU	2.5~3.0kg
MMCK25030Z0	M2.5*3	1	RJ11/45 PCB TO LL SHIELD TO LL	2.5~3.0kg
MMCK25030Z0	M2.5*3	2	MDC MODEN TO MDC MODEN STANDOFF	2.5~3.0kg
MMCK25030Z0	M2.5*3	1	LCD WIRE TO UP	2.5~3.0kg
MMCK20030Z0	M2.0*3	2	BLUETOOTH BOARD TO BLUETOOTH STANDOFF	2.0~2.5kg
MMCK20030Z0	M2.0*3	2	FIX BAY BRACKET WITH DRIVER	2.0~2.5kg
MM000000200	M2.5*3.6 (SPECIAL SCREW)	1	MINI PCI BRACKET TO LOG LOW	2.5~3.0kg
MM000000300	M2.5*3.6 (SPECIAL SCREW)	1	MINI PCI BRACKET TO LOG LOW	2.5~3.0kg
ECTQ0069000	(SPECIAL SCREW)	1	RAM DOOR TO LOG LOW	2.5~3.0kg

Appendix G Reliability

The following table shows MTBF (Mean Time Between Failures) for each component.

Table G-1 MTBF

Component	Time (hours)
LCD	50,000
Keyboard	40,000
HDD	300,000
Removable FDD	30,000
Optical (DVD/CD) drive	60,000
AC adaptor	60,000

